

ELETTROPOMPE PER PISCINA  
SWIMMING POOL PUMPS

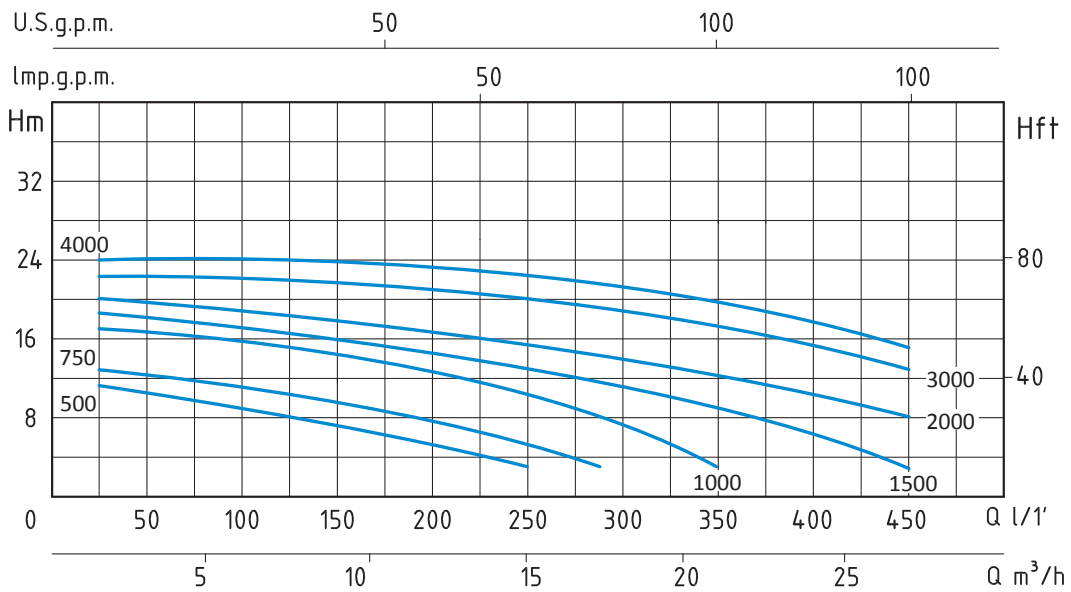

**TSW - 50 HZ - 1 PHASE / 3 PHASE**

TIPO- TYPE		POTENZA NOMINALE NOMINAL POWER		POTENZA ASSORBITA INPUT POWER	AMPERE		Q = PORTATA- CAPACITY												
Monofase Single-phase	Trifase Three-phase	P2		P1	Monofase Single-phase	Trifase Three-phase	m³/h	1,5	3	4,5	6	9	12	15	16,5	18	21	24	27
		HP	KW	KW			lt/1'	25	50	75	100	150	200	250	275	300	350	400	450
Prevalenza manometrica totale in m.C.A.- Total head in meters w.c.																			
TSW 500		0,5	0,37	0,6	2,8		11	10,5	10	9	7	5	2,5						
TSW 750		0,75	0,55	0,75	3,5		13	12,5	12	11,5	10	7,5	4,5	3					
TSW 1000		1	0,75	1,15	5,1		17	16,5	16	15,5	14,5	13	10	8,5	7	3			
TSW 1500		1,5	1,1	1,4	6,2		18	17,5	17	16,5	15,5	14,5	13	12	11	9	6	3	
TSW 2000		2	1,5	1,43	6,3		20	19	18,5	18	17,8	17	15,7	14,8	14	12	10	8	
TSW 3000		3	2,2	2	9	3,7	22,4	22,2	22,1	22	21	20,5	20	19	18	17	15	13	
TSWt 4000T		4	3	2,4		4,3	24	23,5	23,3	23	22,8	22,5	22	21	20	19	17,5	15	

## APPLICAZIONI

Elettropompe autoadescanti Jet garantiscono un'ottima resa idraulica e una notevole capacità di portata. Possono aspirare fino a 8 mt. di profondità e sono in grado di funzionare perfettamente anche in presenza di acque miscelate a gas. Adatte per il sollevamento e la distribuzione negli impianti di depurazione delle piscine.

## LIMITI D'IMPIEGO

- Temperatura liquido fino a 35°C (per un uso domestico secondo EN 60335-2-41)
- Temperatura max. liquido: 35°C (per altri impieghi)
- Temperatura ambiente fino a 40°C
- Servizio continuo

## MOTORE

- Monofase 230V-50Hz
- Trifase 230/400V-50Hz
- Motore elettrico ad induzione a 2 poli (n = 2850 min<sup>-1</sup>)
- Isolamento Classe F
- Protezione IPX 5

## MATERIALI

- Corpo pompa Polipropilene
- Supporto motore Alluminio
- Girante Noryl
- Filtro cestello Polipropilene
- Tenute meccaniche Silicio/Silicio/NBR

## APPLICATION

Selfpriming jet water pumps with a very high hydraulic performance and a considerable capacity.

Able to pump up to mt. 8 depth and work perfectly even in so-da-water. Suitable for water lifting and distribution in purification systems for swimming pools..

## OPERATING CONDITIONS

- Liquid temperature up to 35°C (for home use according to EN 60335-2-41)
- Temperature max. liquid: 35°C (for other uses)
- Ambient temperature up to 40°C
- Continuous duty

## MOTOR

- Single-phase 230V-50Hz
- Three-phase 230/400V-50Hz
- Two-Pole induction motor (n = 2850 min<sup>-1</sup>)
- Insulation Class F
- Protection IPX 5

## MATERIALS

- Pump body Moplen
- Motor Support Aluminium
- Impeller Noryl
- Filter basket Moplen
- Mechanical seal Silicon/Silicon/NBR

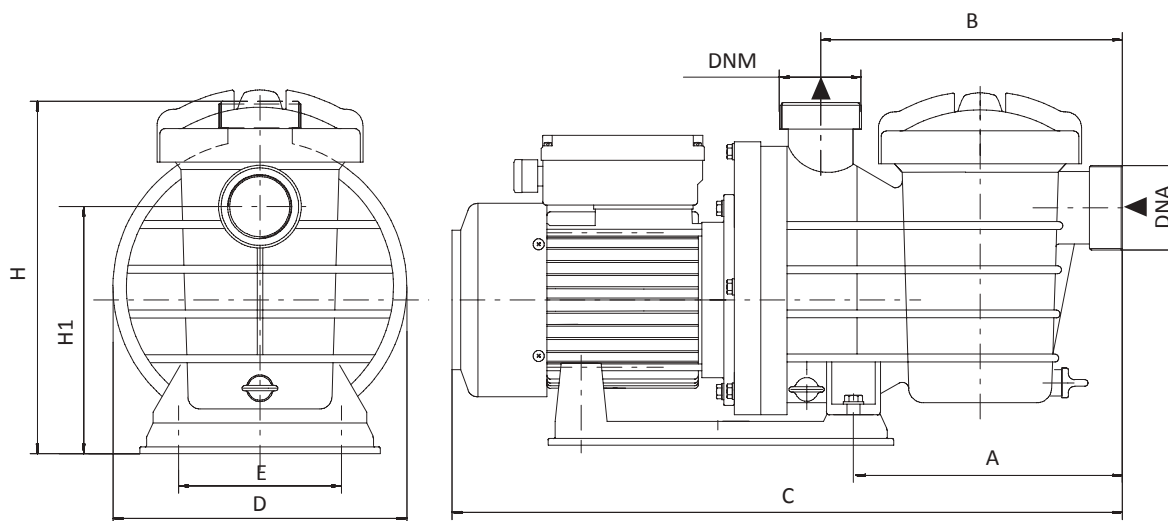

TIPO TYPE		DIMENSIONI mm- DIMENSIONS mm									DIMENSIONI DIMENSIONS mm			PESO WEIGHT
Monofase Single-phase	Trifase Three-phase	A	B	C	D	E	H	H1	DNA	DNM	P	L	H	Kg
TSW 500		77	215	465	160	122	234	153	1" 1/2	1" 1/2	180	510	255	8,7
TSW 750		196	223	502	220	122	270	185	1" 1/2	1" 1/2	241	530	288	10,9
TSW 1000		196	223	502	220	122	270	185	1" 1/2	1" 1/2	241	530	288	12,2
TSW 1500		211	230	520	238	159	331	225	2"	2"	255	554	355	12,9
TSW 2000		274	290	600	270	195	330	225	2"	2"	300	630	390	16,2
TSW 3000	TSWt 3000T	274	290	600	270	195	330	225	2"	2"	300	645	400	17,5
	TSWt 4000T	274	290	645	270	195	330	225	2"	2"	300	670	400	18,5