

ELETTROPOMPE SOMMERSE INOX PER ACQUE LURIDE
INOX SUBMERSIBLE SEWAGE PUMPS



130



550

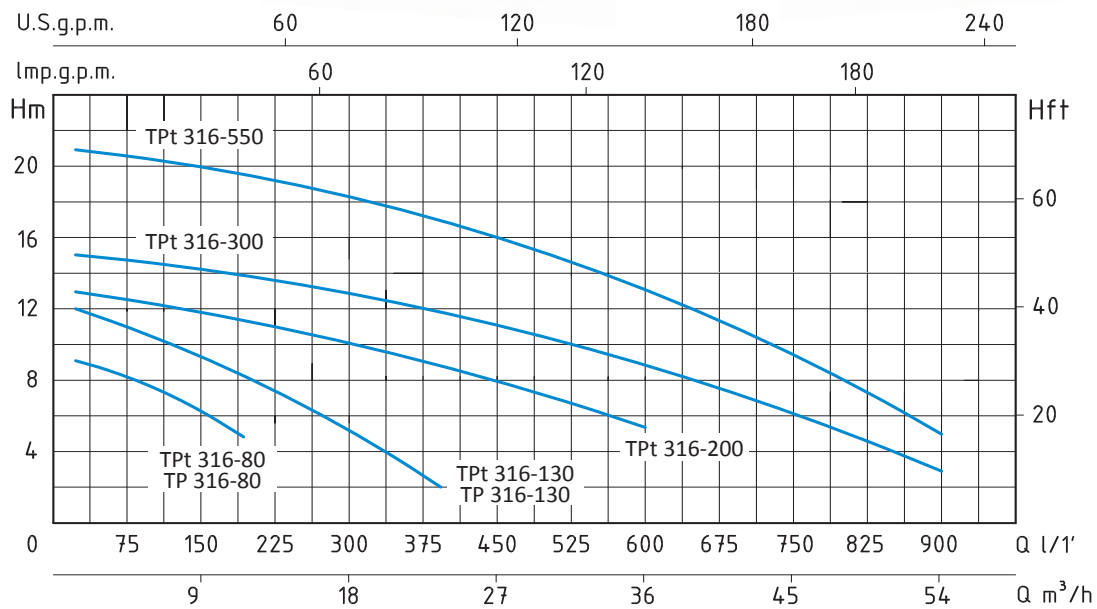

TP 316 - 50 HZ - 1 PHASE / 3 PHASE

TIPO TYPE		POTENZA NOMINALE NOMINAL POWER		AMPERE		Q = PORTATA - CAPACITY										
Monofase Single-phase	Trifase Three-phase	P2		Monofase Single-phase	Trifase Three-phase	Prevalenza manometrica totale in m.C.A. - Total head in meters w.c.										
		HP	KW			m³/h	1,5	3	6	8	9	12	24	36	48	54
TP 316-80	TPt 316-80	0,8	0,6	3	1	9,2	8,5	7,3	6,3	6,1	5					
TP 316-130	TPt 316-130	1,3	1	4,8	1,9	12	11,7	10,5	9,7	9,2	8	2				
	TPt 316-200	2	1,5		3,5	12,5	11,9	11,4	11,1	10,9	10,5	9	5,4			
	TPt 316-300	3	2,2		5,5	15,7	15,4	15	14,6	14,4	14,2	13	9	5	3	
	TPt 316-550	5,5	4		12,2	21	20,5	20	19,8	19,6	19	16,8	13,8	8	5	

APPLICAZIONI

Elettropompe per drenaggio con girante in acciaio inox che assicura ampi passaggi liberi ed elevate prestazioni. Adatta per la movimentazione di liquidi fognari e biologici carichi, fanghi attivi e per liquidi non depurati da griglie, per scarichi di origine civile ed industriali e per liquidi particolarmente aggressivi, salini e corrosivi.

LIMITI D'IMPIEGO

- Temperatura liquido fino a 35°C (per un uso domestico secondo EN 60335-2-41)
Temperatura max. liquido: 40°C (per altri impieghi)
- Massima profondità d'immersione 10 mt. (per un uso domestico secondo EN 60335-2-41)
- Livello min. d'aspirazione 150 mm
- Servizio continuo

MOTORE

- Monofase 230V-50Hz (con galleggiante)
- Trifase 230/400V-50Hz
- Isolamento Classe F
- Protezione IP 68
- Protettore termico

MATERIALI

- Corpo motore: Acciaio Inox AISI 316
- Corpo pompa: Acciaio Inox AISI 316
- Coperchio superiore: Acciaio Inox AISI 316
- Girante: Acciaio Inox AISI 316
- Cilindro motore: Acciaio Inox AISI 316
- Albero motore: Acciaio Inox AISI 316
- Doppia tenuta meccanica in camera d'olio: Ceramica/Grafite/Viton
Silicio/Silicio/Viton

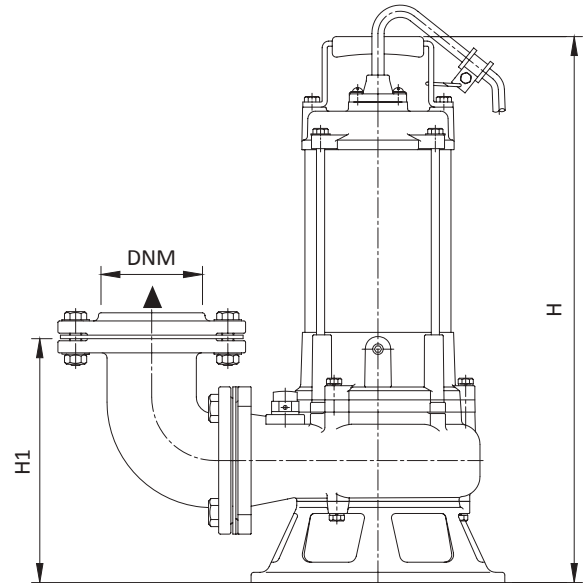
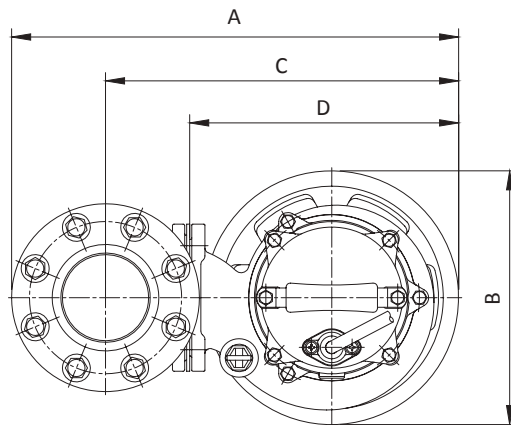

APPLICATION

Submersible drainage pumps with inox impeller, which allows free passage of suspended parts and high performance. Suitable in civil and industrial water systems, for cesspool drainage with dirty and muddy liquids and for waters not cleaned by grid and for particularly aggressive liquids, salt and corrosive.

OPERATING CONDITIONS

- Liquid temperature up to 35°C (for home use according to EN 60335-2-41)
Temperature max. liquid: 40°C (for other uses)
- Maximum immersion depth 10 mt. (for home use according to EN 60335-2-41)
- Min. suction level 150 mm
- Continuous duty

MOTOR

- Single-phase 230V-50Hz (with floater)
- Three-phase 230/400V-50Hz
- Insulation Class F
- Protection IP 68
- Thermic protection

MATERIALS

- Motor body: Stainless Steel AISI 316
- Pump body: Stainless Steel AISI 316
- Upper cover: Stainless Steel AISI 316
- Impeller: Stainless Steel AISI 316
- Casing: Stainless Steel AISI 316
- Shaft with rotor: Stainless Steel AISI 316
- Double mechanical seal in oil chamber: Ceramic/Graphite/Viton
Silicon/Silicon/Viton

TIPO TYPE		DIMENSIONI mm- DIMENSIONS mm								DIMENSIONI DIMENSIONS mm			PESO WEIGHT
Monofase Single-phase	Trifase Three-phase	A	B	C	D	H	H1	DNM	CAVO CABLE	P	L	H	Kg
TP 316-80	TPt 316-80	237	154	199	-	427	99	2"	10 mt H07RNF	200	260	480	18
TP 316-130	TPt 316-130	237	154	199	-	427	99	2"	10 mt H07RNF	200	260	480	20
	TPt 316-200	441	250	348	325	538	241	3"	10 mt H07RNF	280	280	630	36
	TPt 316-300	441	250	348	325	563	241	3"	10 mt H07RNF	280	280	630	37
	TPt 316-550	453	216	360	337	572	192	3"	10 mt H07RNF	440	400	820	54