

The future is straightforward and safe:
Gear units and motors in a modular system

Gearmotors



Another milestone at SEW-EURODRIVE: Safe worldwide standards for each drive solution

This brochure on our new modular system for gearmotors documents once more the values we live by in our company. It shows that you can rely on SEW-EURODRIVE in every respect. Because the new modular system fulfills our brand promise in many ways. It includes technically unique innovations, opens up even more possibilities for selecting the right drive solution, simplifies the configuration of components and provides investment security worldwide.

The redevelopment of the tried and tested DT/DV motor series has turned all gearmotor variants of SEW-EURODRIVE into future-proof innovation carriers of the highest quality. The new AC motor series DR encompasses the entire range of efficiency ratings including energy efficient motors, a logical consequence of the developments in environmental policies worldwide.

In the future, gearmotors from SEW-EURODRIVE will continue to fulfill all standards worldwide. What's more, by integrating them into a standardized modular system, SEW-EURODRIVE has become the first manufacturer to offer energy efficient motors along with conventional AC motors within one series. Each motor includes three brake variants. This ensures a much better price for the energy efficient motor. Last but not least, the DR series is the best SEW-EURODRIVE motor that has ever been launched.

Driving the world – with innovative drive solutions for all branches of industry and for every application. Products and systems from SEW-EURODRIVE for any application – worldwide. SEW-EURODRIVE products can be found in a variety of industries, e. g. automotive, building materials, food and beverage as well as metal-processing. The decision to use drive technology “made by SEW-EURODRIVE“ stands for safety regarding functionality and investment.





At the same time, the new motor series offers the same advantages that have made the DT/DV series successful in millions of drive solutions worldwide. These include, above all, power, compact design, versatility, reliability and long service life. Together with many other benefits, also in combination with our drive electronics components, they have turned our gearmotors into what they are today:

state-of-the-art drive technology.

This brochure gives you a complete overview of all possible gearmotor variants. The content is divided into gear units, motors and accessories / options. At the end of each section, clearly structured tables give an overview of matching components for your individual drive solution.



The area of application for our gear units: the world

We do not exaggerate when we proudly say: There is no industry and no drive application in the world for which our gear units in combination with the required motors would not offer excellent performance. Areas of application include automotive engineering, the food and beverages industry, logistics (airport logistics, intralogistics and port logistics), the wood processing, construction and construction materials industries, and countless special applications, e.g. in theaters.

Depending on power requirements, space and technical specifications, SEW-EURODRIVE offers the full range of gear units in a modular system:

helical, parallel shaft helical, helical-bevel, helical-worm, and SPIROPLAN® right-angle gear units. Input covers, motor adapters and various clamping joints in line with the gear unit family are also available from SEW-EURODRIVE.

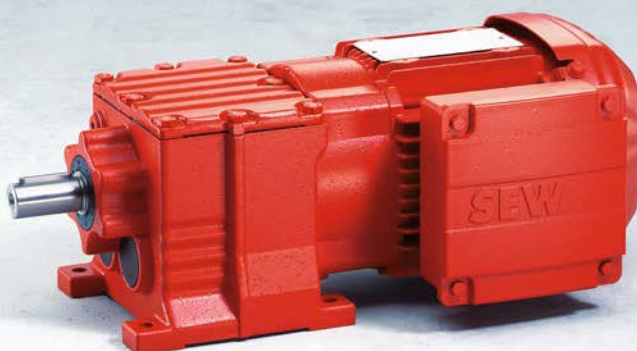

Helical gear units (R): always the optimum space/performance ratio

Six single-stage and fourteen two- and three-stage sizes covering a power range from 50 to 18,000 Nm: Our helical gear units always offer an optimum equilibrium between performance and space requirements. The fine graduation

and variety of torque ratings and gear ratios is peerless. They also satisfy demands for high output speeds or low weight due to the many available sizes.

The result: one helical gear unit will always fit.

Helical gear units (R)

Type	Maximum output torque [Nm]	Gear ratio [i]	Gear ratio multi-stage gear unit [i]
RX series (single-stage) Sizes 57 / 67 / 77 / 87 / 97 / 107	69 ... 830	1.30 ... 8.65	–
R series (two- and three-stage) Sizes 07 / 17 / 27 / 37 / 47 / 57 / 67 / 77 / 87 / 97 / 107 / 137 / 147 / 167	50 ... 18,000 (also with reduced backlash)	3.21 ... 289.74	90 ... 27,001
RM series (two- and three-stage) Sizes 57 / 67 / 77 / 87 / 97 / 107 / 137 / 147 / 167	450 ... 18,000	4.29 ... 289.74	134 ... 27,001



The gear units series R are available in the following designs:

- Single or multi-stage
- Foot or flange-mounted version
- Foot and flange-mounted version
- Flange-mounted design with extended output bearing hub

Parallel shaft helical gear units (F): tailor-made for adverse space conditions

The particularly slim-fit parallel shaft helical gear units are used wherever space is limited. Various mounting positions and designs make for a large range of applications even under adverse conditions. Thanks to its construction characteristics

and its large torque range from 120 to 18,000 Nm, this standard gear unit is an ideal solution for many materials handling and process engineering applications.

Parallel shaft helical gear units (F)

Type	Maximum output torque [Nm]	Gear ratio [i]	Gear ratio multi-stage gear unit [i]
F series (two- and three-stage) Sizes 27 / 37 / 47 / 57 / 67 / 77 / 87 / 97 / 107 / 127 / 157	120 ... 18,000 (also with reduced backlash)	3.77 ... 281.71	87 ... 31,434



Helical-bevel gear units (K): strong performance and high efficiency in a very compact design

The compact design of all our gear units is most obvious in our helical-bevel gear units. They are sophisticated right-angle gear units for all engineering applications that require space-saving installation. At the same time, they provide a powerful torque range from 200 to 50,000 Nm.

They ensure a remarkably high degree of efficiency of more than 96 per cent in both torque directions and for any input speed. A gear unit built to last: The gearing is designed for high endurance and thus makes for a high-torque, wear-free drive.

Helical-bevel gear units (K)

Type	Maximum output - torque [Nm]	Gear ratio [i]	Gear ratio multi-stage gear unit [i]
K series Sizes 37 / 47 / 57 / 67 / 77 / 87 / 97 / 107 / 127 / 157 / 167 / 187	200 ... 50,000 (also with reduced backlash)	3.98 ... 197.37	94 ... 32,625



The gear unit series F and K are available in the following designs:

- Foot or flange-mounted version
- B5 flange-mounted version
- B14 flange-mounted version
- With solid shaft or hollow shaft
- With hollow shaft with keyed connection, shrink disc, splined hollow shaft or TorqLOC®

Helical-worm gear units (S): simple design for increased cost-effectiveness

The strength of the helical-worm gear units is their simple mechanical structure. Tailored individually to torque and speed requirements, they save installation space and costs when implemented in simple applications. In addition to the large gear ratio in the worm gear stage, our helical-worm

gear units also offer a significantly higher level of efficiency than pure worm gear units. Power is transmitted linearly to the drive shaft and the torque shocks are reduced – making for a low noise level.

Their torque range runs from 92 to 4,000 Nm.

Helical-worm gear units (S)

Type	Maximum output torque [Nm]	Gear ratio [i]	Gear ratio multi-stage gear unit [i]
S series Sizes 37 / 47 / 57 / 67 / 77 / 87 / 97	92 ... 4,000	6.80 ... 288.00	110 ... 33,818



SPIROPLAN® right-angle gear units (W): low-noise lightweights

The single-stage SPIROPLAN® right-angle gear-motors deliver their power reliably and quietly: In the power range from 0.09 to 2.2 kW, the SPIROPLAN® series provides output torque ratings up to 180 Nm – its wear-free gearing ensuring very quiet operation. In combination with the compact design and the light-weight

aluminum housing, the noise level is almost perfectly low. The oil filling is independent of the mounting position which means SPIROPLAN® gearmotors can be used universally and are nearly maintenance free. The gear ratio range offers highest output speeds and optimized mechanical efficiency.

SPIROPLAN® right-angle gear units (W)

Type	Maximum output torque [Nm]	Gear ratio [i]	
W10	25	3.91 ... 75.00	
W20	40	6.57 ... 75.00	
W30	70	6.57 ... 75.00	
New: W37	110	3.5 ... 70.00	
New: W47	180	3.5 ... 70.00	



The gear unit series S and W are available in the following designs:

- Foot or flange-mounted version
- B5 flange-mounted version
- B14 flange-mounted version
- With solid shaft or hollow shaft

Additional designs of the gear unit series S:

- With hollow shaft with keyed connection, shrink disc, splined hollow shaft or TorqLOC®

The new motor modular system: one single series for millions of drive combinations

Configuring gearmotors with AC motors from SEW-EURODRIVE has never been easier: A modular system comprising a single series of the new DR motors offers all efficiency levels, including energy efficient motors. In 2002, SEW-EURODRIVE was the first manufacturer worldwide that had managed to use die-cast copper technology in an industrial high-volume production process for the manufacturing of our energy efficient motors.

Other new features in the new modular system are the option to choose between three different brake sizes, depending on the motor size, and cost-optimized encoders built into the motor.

All motor optimizations and designs of the new DR series are available for all efficiency classes. They comply with all worldwide standards and already fulfill the forthcoming IEC standard. For planners and users, they offer a number of unique benefits.

Overview of benefits

- Very simple configuration and ordering
- Configuration of all motor variants from one single series
- Even more options, even fewer restrictions
- Saves space and costs due to compact design
- Future-proof, also from an environmental point of view (regulations)
- Reduced prices for energy efficient motors due to integration
- Reduced prices due to selection of different brake sizes



The efficiency classes of the future

The efficiencies of the energy efficient motors from SEW-EURODRIVE comply with international limit values and standards, often they exceed the requirements.

The list of regulations comprises:

- **Europe** CEMEP, renewed voluntary agreement
- **Australia/New Zealand** MEPS 2006
- **USA** EPAAct 1992
- **Canada** CSA C390
- **Brazil** NBR7094, PROCEL

IE3	<h3>Premium Efficiency</h3> <p>Australia, New Zealand, USA and Canada</p> <ul style="list-style-type: none"> – Very high efficiency level – 4-pole AC motors of the DRP type (energy efficient motors): Motor size 90 and larger: 0.75 ... 200 kW – Copper or aluminum die-cast cage
IE2	<h3>High Efficiency</h3> <p>Europe, Australia, New Zealand, USA, Canada, Brazil</p> <ul style="list-style-type: none"> – High efficiency level – 4-pole AC motor of the DRE type (energy efficient motors): Motor size 80 and larger: 0.75 ... 200 kW – Copper or aluminum die-cast cage
IE1	<h3>Standard Efficiency</h3> <p>Europe, Asia, Africa, Central and South America without Brazil</p> <ul style="list-style-type: none"> – Improved efficiency level – 4-pole AC motors of the DRS type (standard motors): Motor size 71 and larger: 0.37 ... 200 kW – Copper or aluminum die-cast cager

For technical data, please refer to page 20.

Brake variants in the modular system

Smaller holding torques are required for inverter operation. An energy efficient motor requires less braking work. Today's brakes are often dimensioned too large for this purpose.

This is why the new motor modular system from SEW-EURODRIVE makes it possible to choose from up to three brake sizes for each motor size (overview on page 21).

Additional features of the brake are

- Manual brake operation
- Automatic disengaging
- Lockable
- Monitoring of
 - Function
 - Wear



The built-in encoder is fully integrated into the motor

For many applications it is sufficient to detect the speed or a position. For this purpose, complex and expensive mounted encoders or elaborate proximity sensors have been used in the past.

The new and cost-optimized solution from SEW-EURODRIVE is a built-in encoder. It is fully integrated into the motor and connected inside or at the motor terminal box. Due to its simple structure, the built-in encoder can be retrofitted.



Mounting flexibility also on the input end

SEW-EURODRIVE offers optimum solutions for the input end in line with the gear unit family, to provide more flexibility and efficiency also on the side of the motor. Input covers and motor adapters are characterized by compact dimensions, low weight and long service life. Tailored specifically to our gear units, these components ultimately increase the economic efficiency of the drive as a whole.

SEW-EURODRIVE offers eight different cover sizes for different power ratings. These options enable optimum connection of the drive components depending on the gear unit and the drive task. Take the height adjustment for covers, for

example, with a height-adjustable motor mounting platform that allows for simple installation and startup. Or the integrated backstop, which ensures compact drive design and optimum operating characteristics.



The input covers and adapter variants are excellent examples to show how our gear units can increase efficiency in any drive anywhere.

Adapters open up more possibilities

In addition to the integrated torque limiting coupling, there is an adapter variant with integrated hydraulic centrifugal coupling. It is equipped with protection against overheating as standard. An integrated mechanical brake and an integrated backstop are optional. With the AM motor adapters, all IEC motors size 63

to 280 and all NEMA motors size 56 to 365 can be mounted to the 7-series gear units.

The AQ adapter accepts servomotors – either servomotors with positive key connection (AQA) or non-positive connection with a clamping ring hub (AQH).



Installation does not get much easier: The TorqLOC® hollow shaft mounting system

Simple

The new design of the TorqLOC® mounting system makes for simple assembly and dramatically improves removal of the drive even after lengthy periods of operation. SEW-EURODRIVE will deliver the drive with the bushing for the respective diameter. The operator will install the clamping ring on the customer shaft and the drive can be simply mounted and fixed. The installation is simple and fast because there are no interference fits that have to be overcome. Removal will be just as simple and takes place in reverse order.

Economical

The TorqLOC® mounting system makes it possible to use drawn, unprocessed material all the way to quality level h11 for customer shafts, reducing costs even further. No additional machining of the customer shaft required!

Flexible

A well thought-out product down to the smallest detail: Up to four different rated diameters can be adapted with one gear unit size, resulting in a reduction of variants.

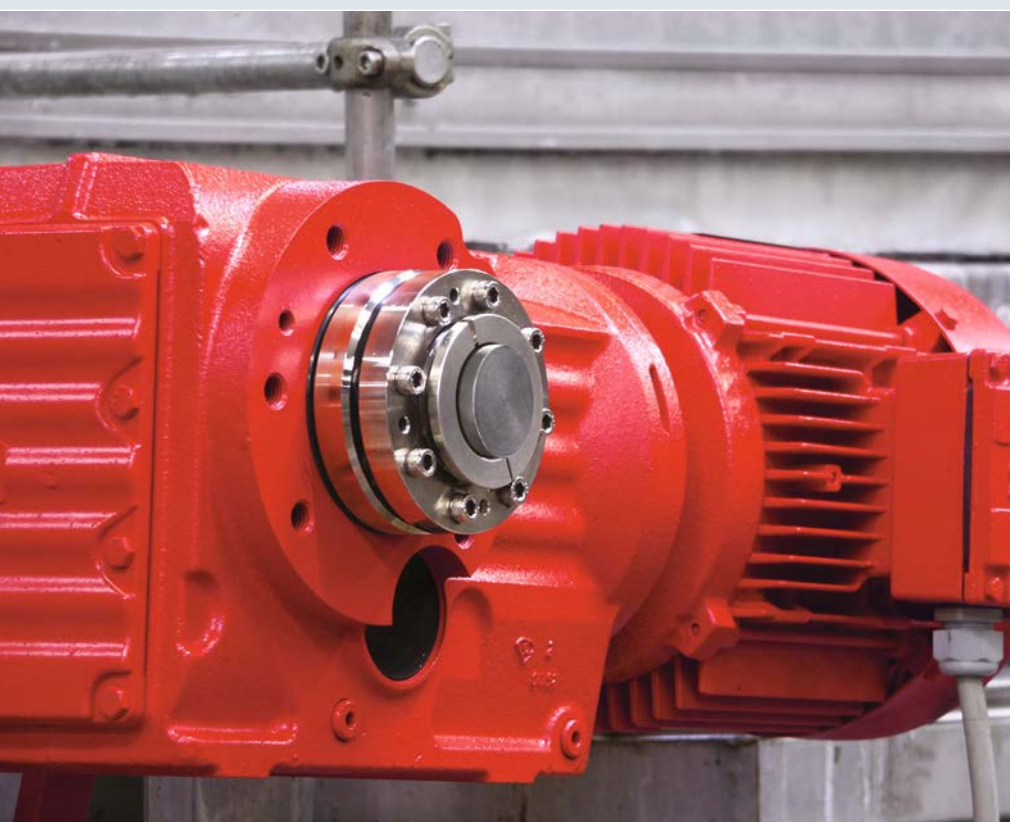

Awards

The trade journal "Plant Engineering" has awarded the "Product of the Year 2002". The award is given to innovative products which lead to ground-breaking improvements at the production level.

SEW-EURODRIVE received the "Silver Award" for TorqLOC® in the category "Power Transmission". The "Silver Award" was handed out at the National Plant Engineering Show in Chicago in early March 2003.

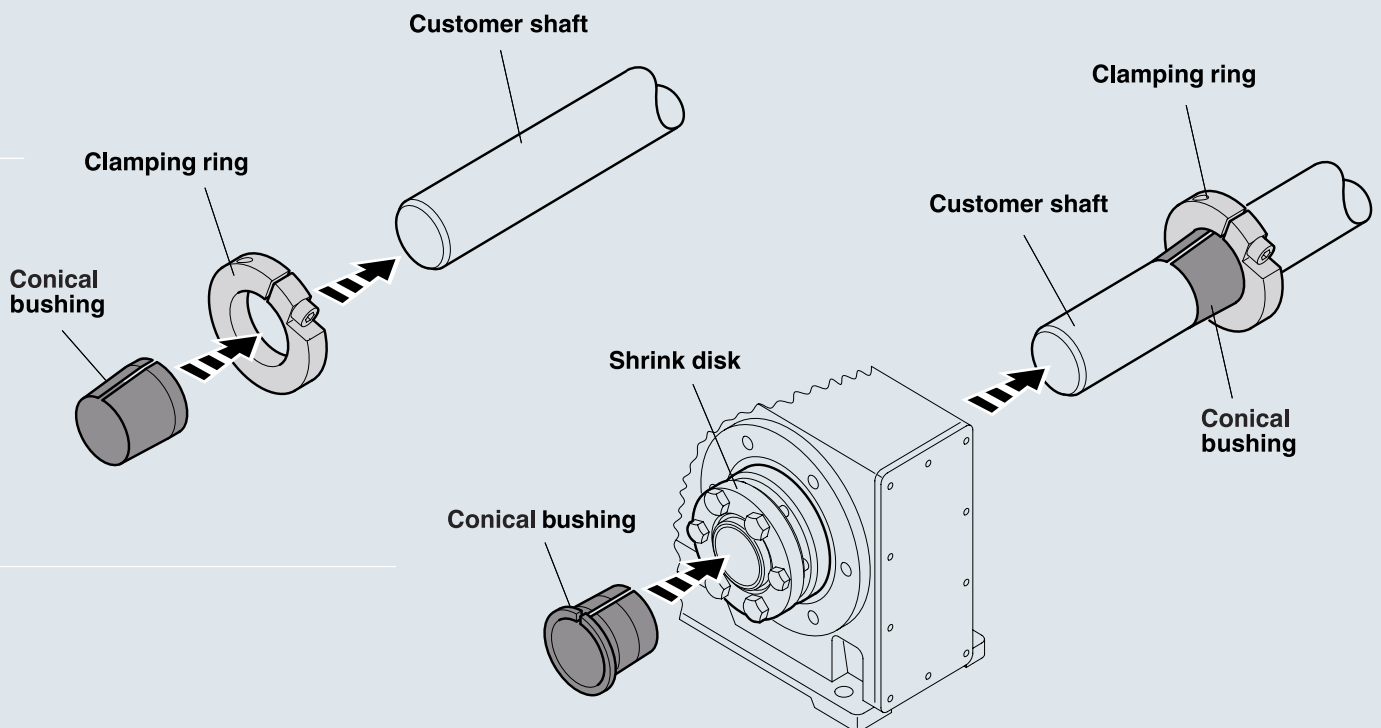

All you need is a PC to discover our range of almost unlimited possibilities

Printed documentation, CD-ROMs or downloads: As diverse as the product range of SEW-EURODRIVE are the tools supporting the designer in the planning and design phase. The comprehensive information material and the product-supporting software are a fast and simple tool for drive selection and its integration in the machine or system design.

Order or download in the Internet

The series of publications entitled "Drive Engineering – Practical Implementation," such as volume 1 "Project Planning for Drives,"

different product documentation (Docu ROMs) and presentations (CBI-ROM) on CD-ROM or operating instructions, manuals and catalogs offer detailed basic information.



Workbench

The SEW Workbench is a planning and configuration tool to specify SEW-EURODRIVE products. The user can make use of simple graphical elements to configure even complex systems and check their functionality quickly and easily.

A variety of new functions offers our customers the opportunity to find a drive solution to meet their individual requirements and discuss the results with an SEW-EURODRIVE sales representative.

The SEW Workbench offers catalog selection functions for gearmotors, electronic components and prefabricated cables as well as accessories and options.

Determination of the CAD data ensures the creation of true-to-scale drawings of SEW-EURODRIVE products in the 2D formats DXF and DWG as well as in the 3D formats SAT, STEP, IGES,

VRML, VDAFS and 3D-DXF. Thanks to the high functionality, spare parts lists, mounting position sheets, dimension sheets and operating instructions are determined automatically.

To use SEW Workbench, all you need to do is to register via the SEW-EURODRIVE customer portal DriveGate (<https://portal.drivegate.biz>) once you have received the data DVD. An Internet update service keeps the products and functions up-to-date.

The SEW Workbench is available in the following languages:

German, English, French, Dutch, Spanish, Portuguese, Russian, Czech and Polish.

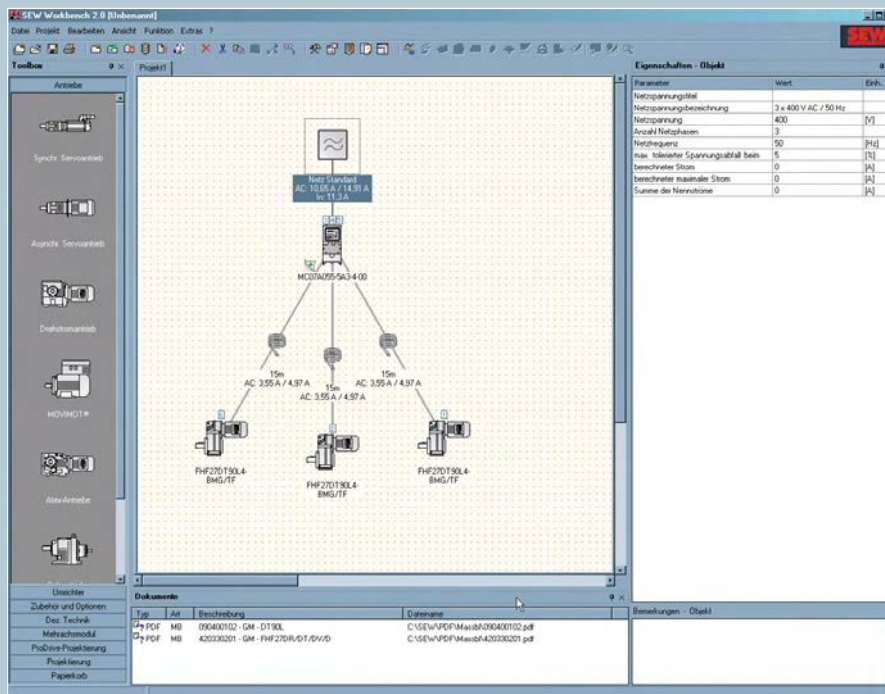

Technical data

DR motors / 50 Hz motor power [kW]

Motor size	Standard motors	Energy efficient motors	
	Standard Efficiency Type DRS	High Efficiency Type DRE	Premium Efficiency Type DRP
DR 71	0.37 ... 0.55	–	–
DR 80	0.75 ... 1.1	0.75	–
DR 90	1.5 ... 2.2	1.1 ... 1.5	0.75 ... 1.1
DR 100	3,0 ... 4.0	2.2 ... 3.0	1.5 ... 2.2
DR 112	4.0	3.0	–
DR 132	5.5 ... 9.2	4.0 ... 7.5	3.0 ... 5.5
DR 160	9.2 ... 15	7.5 ... 11	5.5 ... 7.5
DR 180	15 ... 30	11 ... 22	7.5 ... 18.5
DR 200	30	22	22
DR 225	37 ... 55	30 ... 45	30 ... 45
...
DR 315	110 ... 200	110 ... 200	90 ... 160

DR motors / 60 Hz motor power [kW]

Motor size	Standard motors	Energy efficient motors	
	Standard Efficiency Type DRS	High Efficiency Type DRE	Premium Efficiency Type DRP
DR 71	0.37 ... 0.55	–	–
DR 80	0.75 ... 1.1	0.75	0,75
DR 90	1.5 ... 2.2	1.1 ... 1.5	1.1 ... 1.5
DR 100	3.0 ... 4.0	2.2 ... 3.7	2.2 ... 3.7
DR 112	4.0	3.7	3.7
DR 132	5.5 ... 9.2	4.0 ... 7.5	4.0 ... 7.5
DR 160	9.2 ... 15	7.5 ... 11	7.5 ... 11
DR 180	15 ... 30	11 ... 22	11 ... 22
DR 200	30	22	22
DR 225	37 ... 55	30 ... 45	30 ... 45
...
DR 315	110 ... 200	110 ... 200	90 ... 160

Overview of brake combinations for the DR motor

Motor type	Maximum braking torque [Nm]									
	5	10	20	55	110	200	300	600	1200	2400
DR 71	BE05	BE1	BE2	BE5	BE11	BE20	BE30	BE32	BE62	BE120
DR 80										
DR 90										
DR 100										
DR 112										
DR 132										
DR 160										
DR 180										
DR 200										
DR 225										
...	
DR 315										BE122

Overview of encoder combinations for DR motor

Motor type	Built-in encoder (signal format)			Mounted encoder (signal format)				
	HTL	Sin/Cos	Absolute	Sin/Cos	HIPERFACE® Single-turn	HIPERFACE® Multi-turn	SSI Multi-turn	Other
DR 71	EI7C	EI7S	AI7W	ES7S	ES7H	AS7H	on request	on request
DR 80								
DR 90								
DR 100								
DR 112								
DR 132								
DR 160								
DR 180								
DR 200								
DR 225								
...								
DR 315				EH7S	on request	on request	AH7Y	

Extract from the additional features
of the DR motor modular system

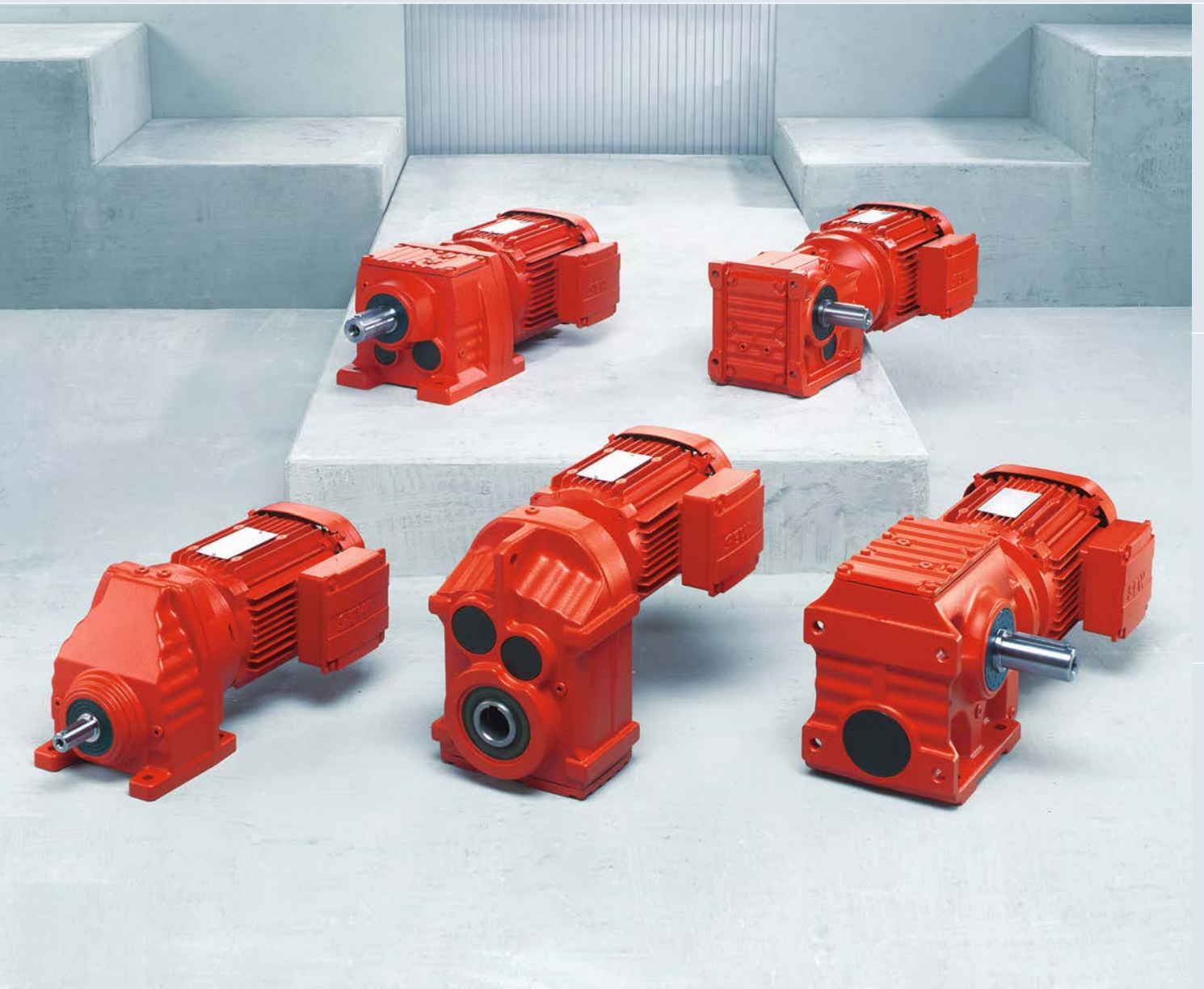

Additional feature	Characteristic	SEW type designation
Brakes		BE with size designation
Manual brake release	Automatic disengaging (BE05-32)	HR
	Lockable (BE05-122)	HF
Brake monitoring	Wear/function	DUB
Built-in encoder (DR71-132)	HTL	EI7C
	Sin/Cos	EI7S
	Absolute encoder	AI7W
Shaft-centered mounted encoder (DR71-225)	Sin/Cos	ES7S
	HIPERFACE® Single-turn	ES7H
	HIPERFACE® Multi-turn	AS7H
Shaft-centered hollow shaft encoder (DR315)	Sin/Cos	EH7S
	SSI Multi-turn	AH7Y
Thermal motor protection	3 PTC resistors	TF
	3 bimetallic switches	TH
Temperature measuring	1 or 3 PT100 units	PT
	1 KTY84-130 unit	KY
Back stop	Instead of brake; CW or CCW direction of rotation blocked	RS
Plug connectors	Integrated in terminal box	IS
	Mounted (types from Harting)	AC../AS../AM..
Forced cooling fan		V
Protection cowl		C
Air filter		LF
Fan	Metal	AL
	Heavy (additional inertia)	Z
Condensation drain holes		DH
Second shaft end		2W
MOVIMOT® (DR71-100)		MM with size designation
MOVI-SWITCH® (DR71-100)		MSW