

Pro-Flo® Series

simple.reliable.efficient.



WILDEN®

Where Innovation Flows



Pro-Flo® Series

As the industry's workhorse, the Wilden Pro-Flo® Series combines elegant simplicity with robust and reliable performance that end users have come to depend on for more than 20 years. Ideally suited for industrial applications calling for a durable chemical pump or oil pump, Pro-Flo Series pumps offer increased productivity with more flow while reducing air consumption and maintenance. The Pro-Flo Series gives you extreme flexibility and reliability – with a wide range of sizes and material offerings – that end users can count on to deliver the consistent performance promised for challenging applications.

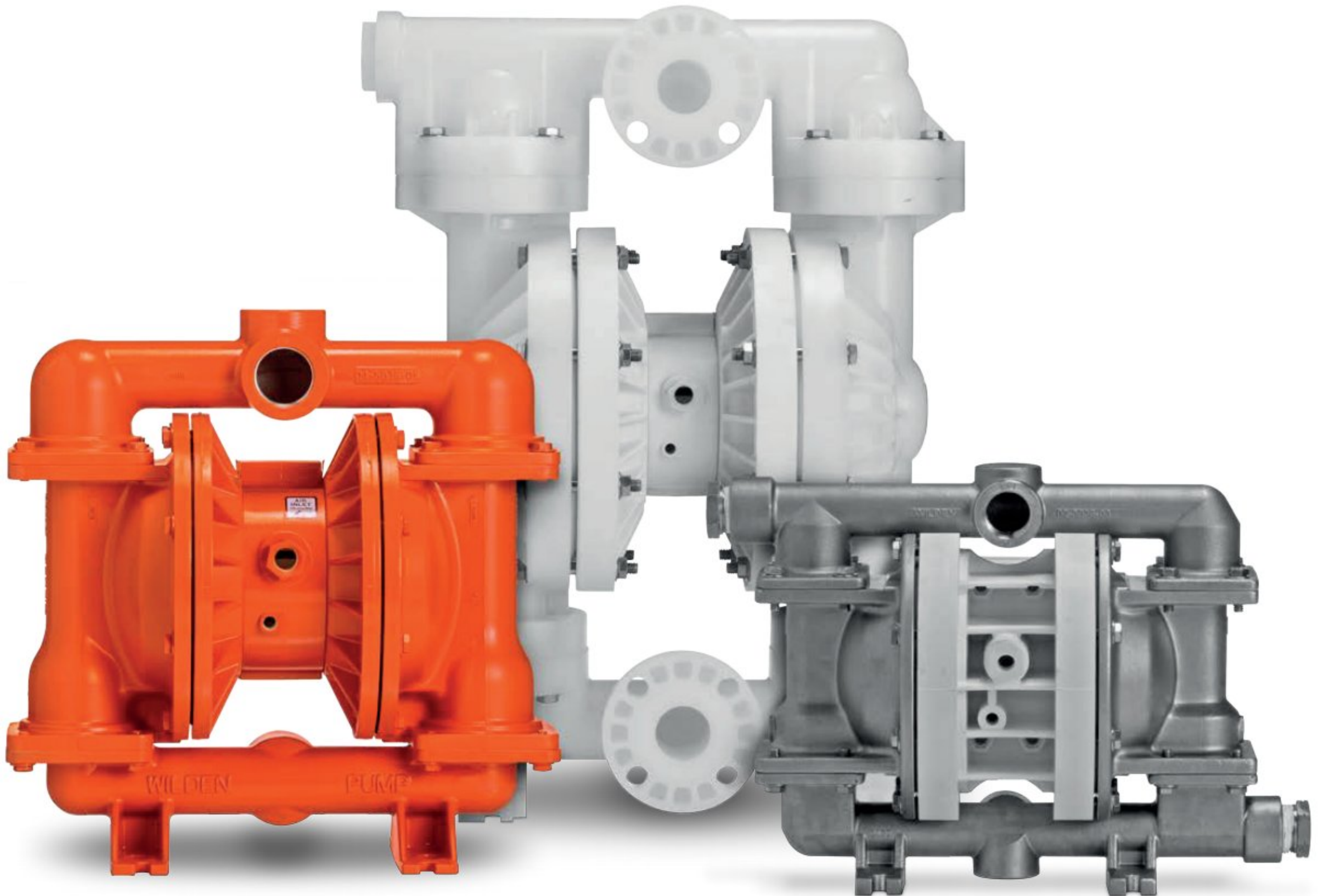



The secret to the success of Pro-Flo Series pumps is the incorporation of a simple and durable Air Distribution System (ADS) that features a plastic center block and lube-free operation. The patented Pro-Flo ADS incorporates three moving parts: the unbalanced air valve spool, the pilot spool and the main shaft/diaphragm assembly for simplicity and high reliability.

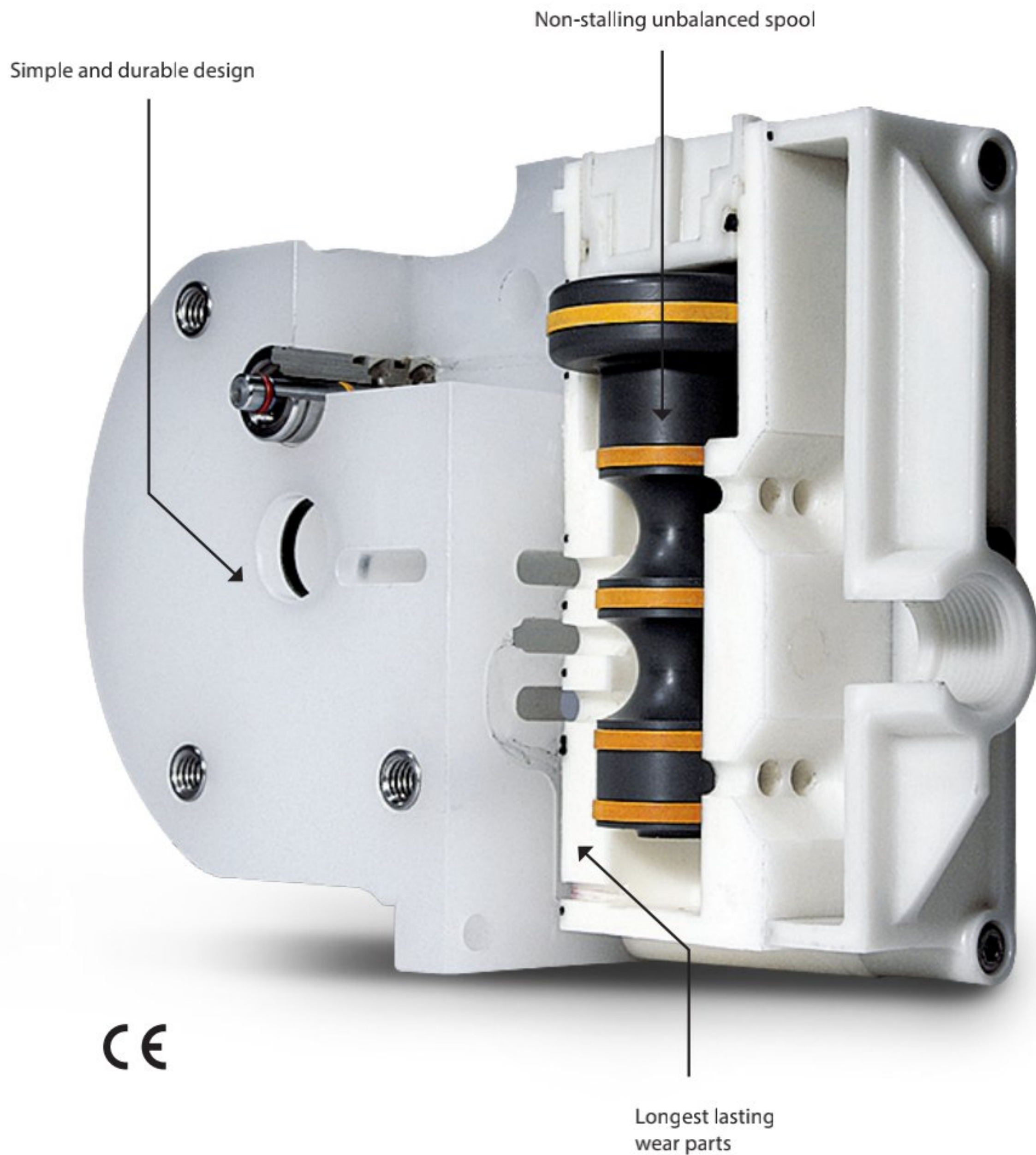

Working Principle of Wilden AODD Pumps

Wilden AODD pumps are reciprocating, positive-displacement-style pumps driven by compressed air. The following drawings and information detail the liquid flow pattern through the pump from its initial unprimed position.

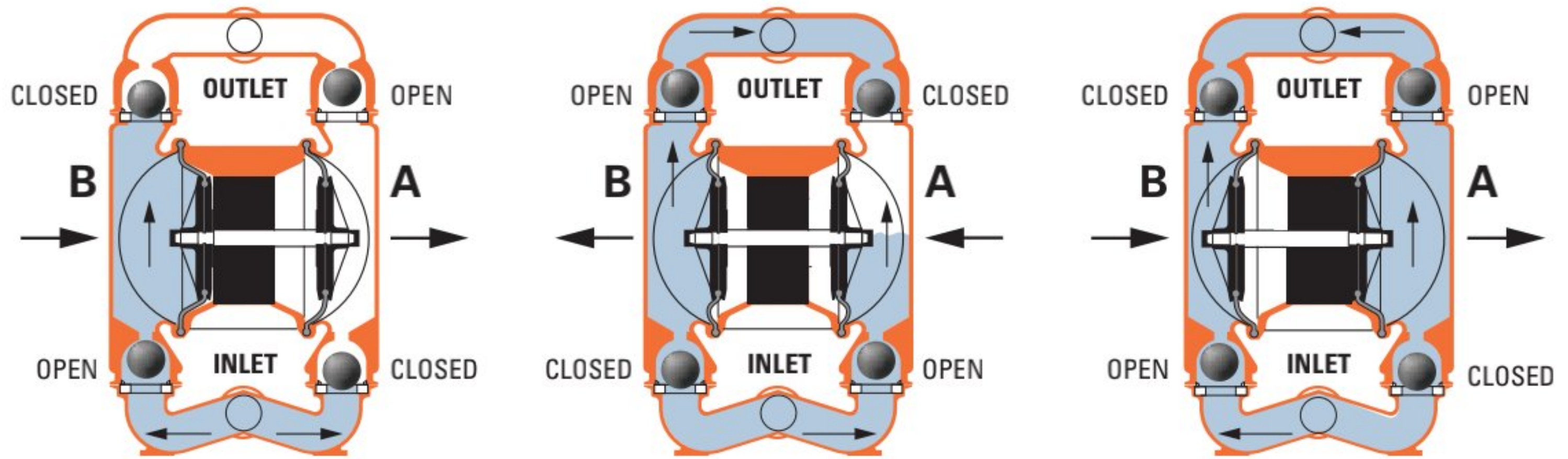

1. The air valve directs pressurized air to the back side of Diaphragm A.
 2. The compressed air moves the diaphragm away from the center of the pump.
 3. Diaphragm B is pulled in by the shaft connected to the pressurized Diaphragm A.
 4. Diaphragm B is now on its suction stroke. The movement of Diaphragm B toward the center of the pump creates a vacuum within chamber B and causes the atmospheric pressure to force fluid into the inlet manifold forcing the inlet valve ball off its seat.
 5. When the pressurized diaphragm, Diaphragm A, reaches the limit of its discharge stroke, the air valve redirects pressurized air to the back side of Diaphragm B.
 6. The pressurized air forces diaphragm B away from the center while pulling Diaphragm A to the center.
 7. Diaphragm B is now on its discharge stroke. Diaphragm B forces the inlet valve ball onto its seat due to the hydraulic forces.
 8. The hydraulic forces lift the discharge valve ball off its seat, while the opposite discharge valve ball is forced onto its seat, forcing fluid to flow through the pump discharge.
 9. At completion of the stroke, the air valve redirects air to the back side of diaphragm A, which starts diaphragm B on its exhaust stroke.
 10. As the pump reaches its original starting point, each diaphragm has gone through one exhaust and one discharge stroke.
- This constitutes one complete pumping cycle. The pump may take several cycles to completely prime depending on the conditions of the application.

Benefits of AODD Pumps

Thanks to their unique operating principle, AODD pumps excel in a wide variety of applications and incorporate numerous features and benefits, including:

- Self priming
- Portable
- High vacuum
- Lube-free operation
- No mechanical seals - reduces risk of leaks
- Run-dry capable
- No heat generation
- Submersible
- Superior product containment
- Easy installation
- Corrosion resistant
- Longest Mean Time Between Failure (MTBF)
- Anti-freezing



How AODD Compares to Other Pump Technologies

Air-operated double-diaphragm pumps provide a lot of unique benefits to all types of applications and markets.

A = Excellent B = Good C = Fair D = Poor		Shear Sensitivity	Dry-Run Capable	Solids Passage	Maintenance Costs	Submersible
Pump Type	 Wilden AODD Pumps	A	A	A	A	A
	 Vane Pumps	D	B	A	C	D
	 Gear Pumps	D	C	B	D	D
	 Lobe Pumps	A	C	C	D	D
	 Centrifugal Pumps	D	C	B	B	C
	 Peristaltic Hose Pumps	D	A	B	C	D
	 Piston/Plunger Pumps	C	A	C	D	D

Pro-Flo® Applications

Serving the energy, process, hygienic, mining and water and wastewater markets, Wilden's world-class distributor network ensures that you will have access to the latest pump technologies and fluid transfer services available when you need them. To find a distributor closest to you, visit wildendistributor.com.



Wilden Bolted Metal & Plastic Pumps

Wilden bolted metal and plastics pumps are specifically engineered for maximum performance and operational excellence in a variety of applications. Their bolted configuration ensures total product containment while the optimized liquid path reduces internal friction to maximize output and efficiency. Bolted pumps are designed to be a drop-in/fit replacement for current systems.

SIZE AND MATERIAL OPTIONS:

- Sizes: 6 mm (1/4") through 76 mm (3")
- Wetted Path Materials:
 - Metal: Aluminum, Ductile Iron, Stainless Steel, Alloy C
 - Plastic: Polypropylene, PVDF

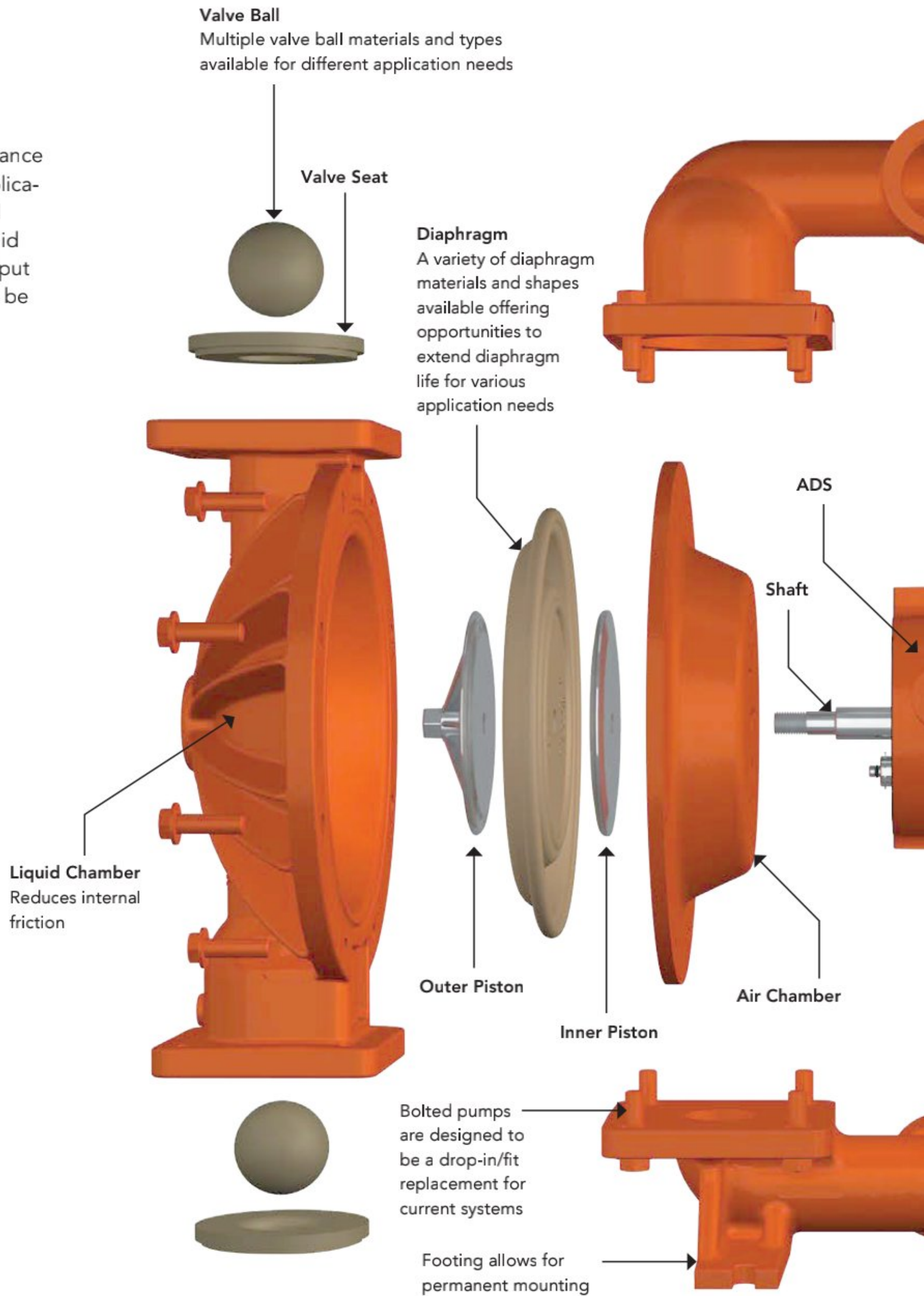

Connection Types

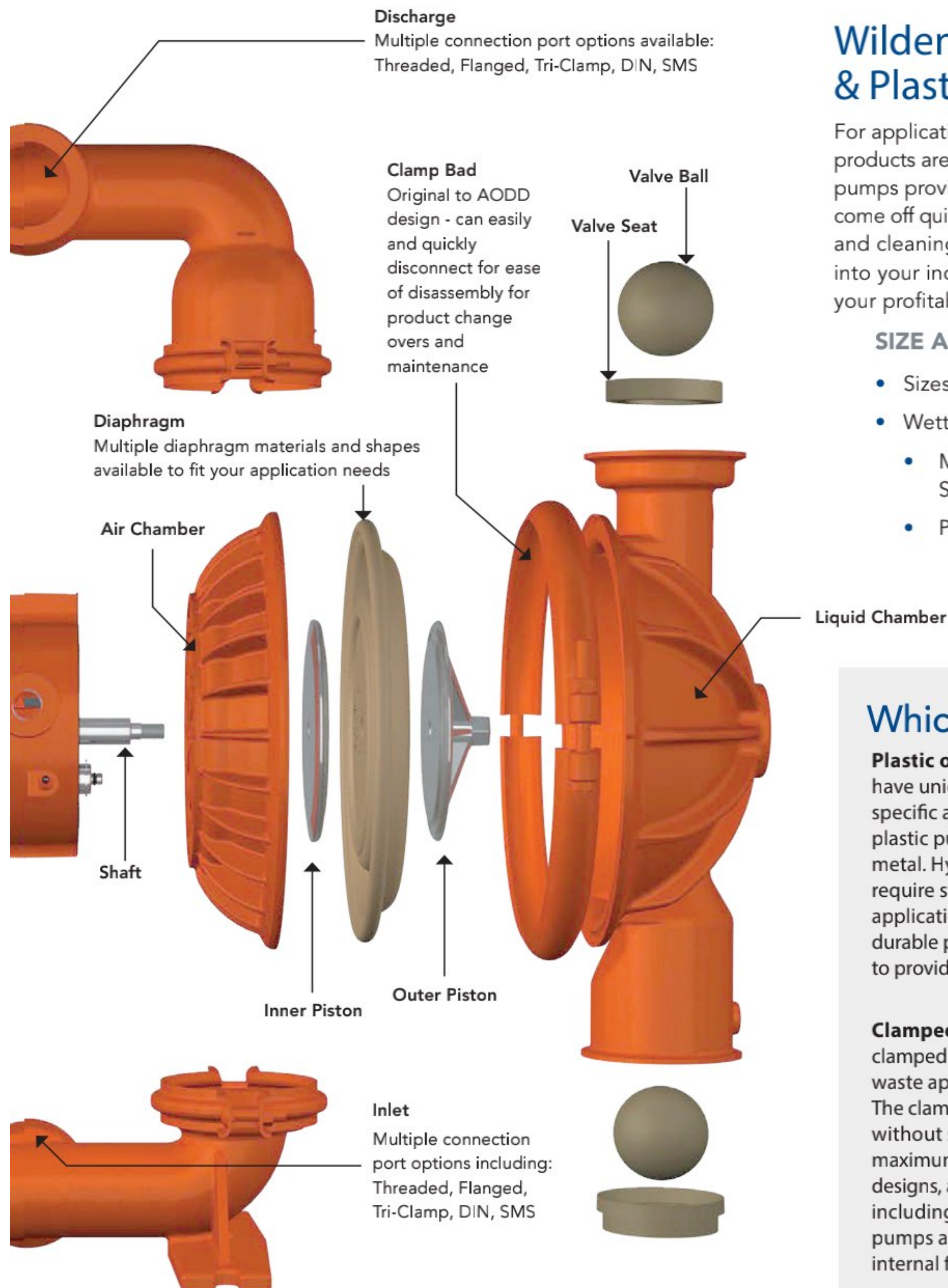

Wilden Clamped Metal & Plastic Pumps

For applications where constant changeovers between products are required, Wilden clamped metal and plastic pumps provide ease of maintenance. The clamp bands come off quickly and easily for replacement of diaphragms and cleaning. The lower downtime translates directly into your increased productivity and contributes to your profitability.

SIZE AND MATERIAL OPTIONS:

- Sizes: 6 mm (1/4") through 51 mm (2")
- Wetted Path Materials:
 - Metal: Aluminum, Ductile Iron, Stainless Steel
 - Plastic: Polypropylene, PVDF

Which Pump Is Right For Me?

Plastic or Metal? – Plastic and metal pumps each have unique benefits and characteristics suited for your specific application needs. For chemical processes, plastic pumps typically provide greater resistance than metal. Hygienic processes on the other hand tend to require stainless steel. Additionally, general industrial applications benefit from aluminum and ductile iron's durable properties. Wilden has multiple material options to provide the exact pump needed for your application.

Clamped or Bolted? – The original AODD pump design, clamped pumps, lend themselves to various process and waste applications, as well as construction and mining. The clamped configuration provides easier maintenance without sacrificing reliability. Bolted pumps deliver maximum process fluid containment over clamp-banded designs, and can be used for a wide range of applications, including oil and gas, paints and inks, and acids. Bolted pumps also offer a redesigned liquid path that reduces internal friction to maximize output and efficiency.

Integral Piston Diaphragms (IPDs)

Wilden IPDs offer safe, clean and reliable product transfer with no product entrapment areas to minimize product contamination and risk liabilities. These diaphragms have a smooth, contoured shape and no outer piston. IPDs have greater durability and flex life and are compatible with existing shafts and supporting hardware. They also provide greater flow rates and faster installation.

CHEM-FUSE INTEGRAL PISTON DIAPHRAGM

Chem-Fuse diaphragms are the ideal solution for general industrial and chemical applications. Incorporating the core patented technology of Wilden's integral piston design, Chem-Fuse diaphragms solve many of the critical issues faced by industrial companies that use conventional diaphragms without sacrificing performance. This diaphragm features a wide range of temperature limits, excellent flex life, high abrasion resistance and outstanding durability, even when handling acids, caustics and other aggressive fluids. Additional benefits include:

- Up to 100% increased flow and suction lift compared to PTFE laminate diaphragms
- Elimination of potential leak point increases containment and safety when pumping critical or dangerous fluids
- Available in: Wil-Flex™ material
- Available sizes: 25 mm (1"), 38 mm (1-1/2"), 51 mm (2"), 76 mm (3")

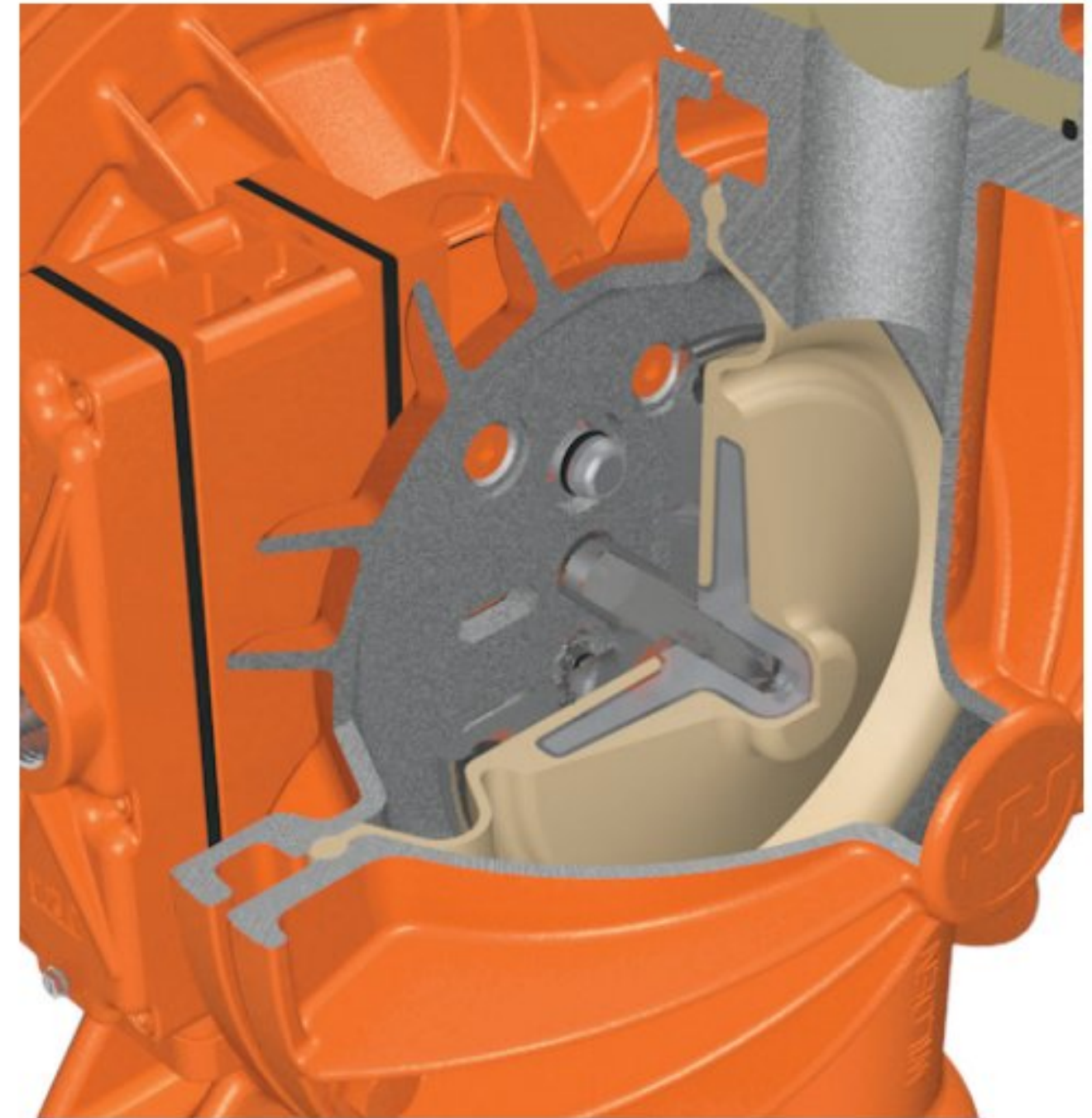

STANDARD DIAPHRAGM

GOOD

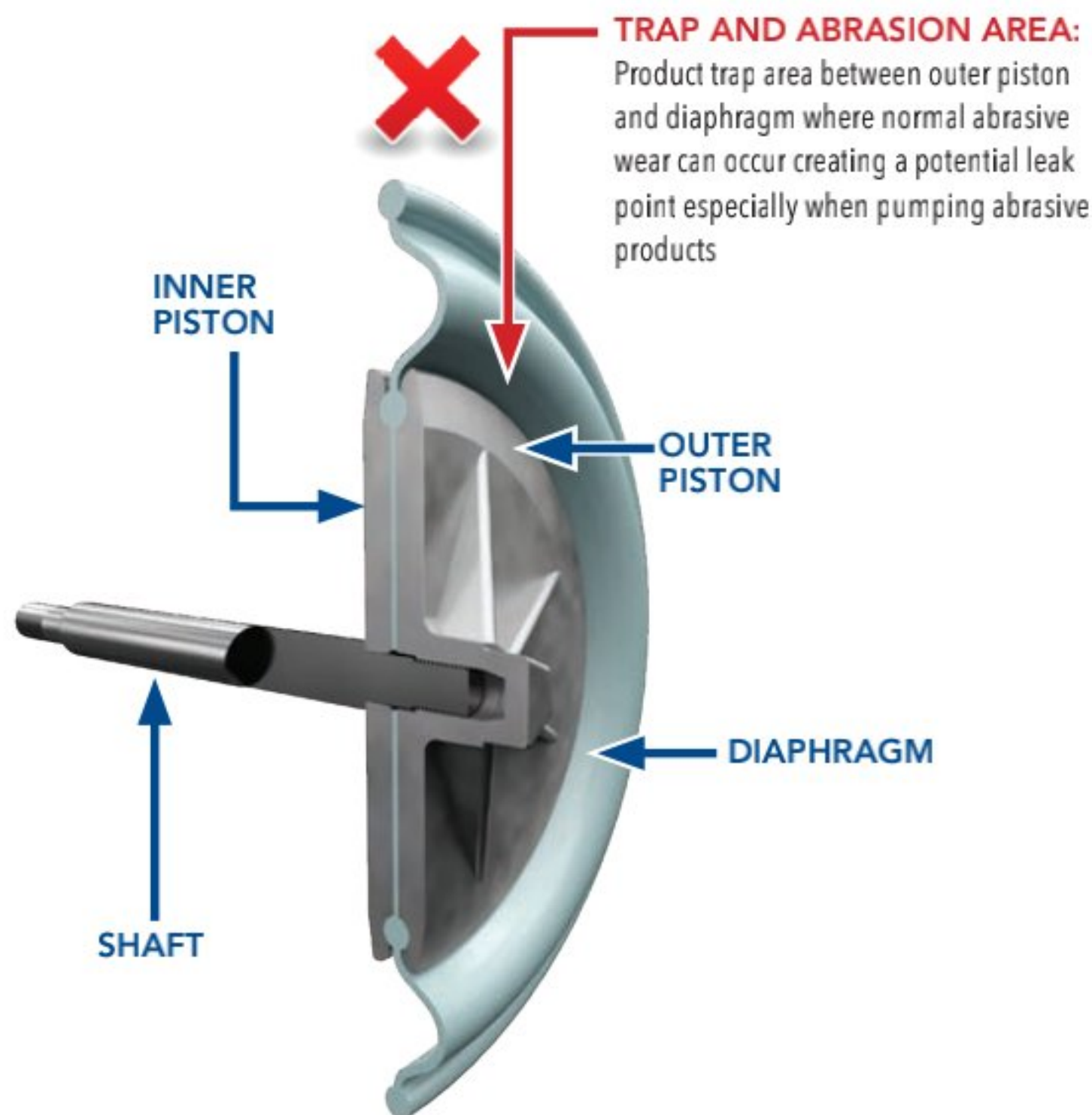

CHEM-FUSE DIAPHRAGM

BEST

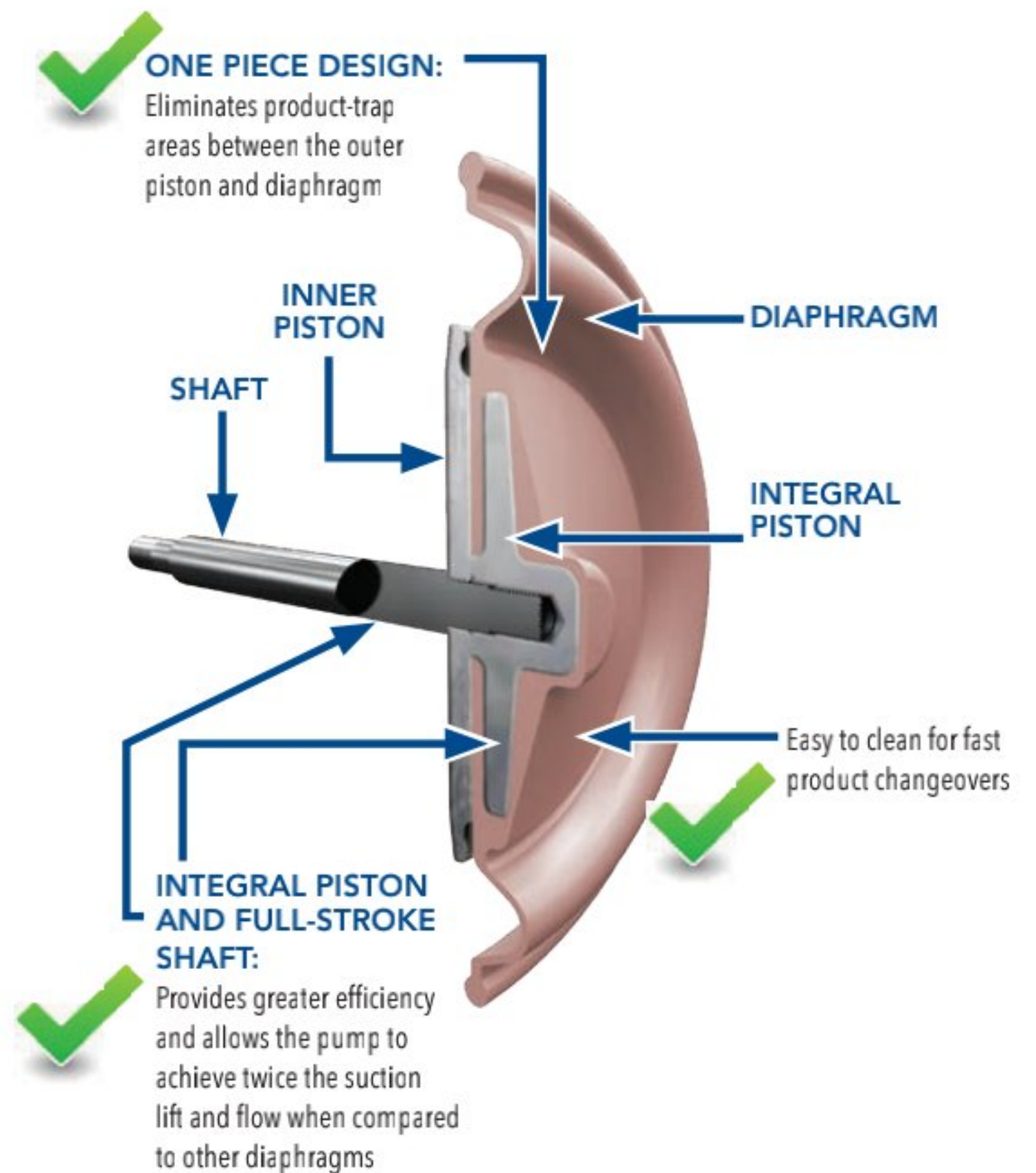

In addition, Wilden also offers a variety of other diaphragm options, including:

EZ-INSTALL

- Convolute shape allows quick, easy installation and minimizes risk of injury
- Decreased downtime and costs of diaphragm replacement
- Available in: Thermoplastic Elastomers (TPE) Wil-Flex, Saniflex™, Polyurethane and Geolast®
- 100% compatible with existing hardware

PTFE ELASTOMERS

- Optimal choice for aggressive chemical applications
- Excellent flex life, good abrasion resistance and durability
- Available in Reduced-Stroke PTFE and Full-Stroke PTFE

RUBBER ELASTOMERS

- General purpose diaphragm
- Provides the greatest temperature spans
- Increased chemical resistance
- Available in Buna-N, EPDM, Neoprene, and FKM

ULTRA-FLEX™

- Utilizes longest-lasting rubber-compound diaphragm in the industry
- Reduces internal stress for long diaphragm life
- Increased abrasion resistance with corrosive materials



Accessories

Wilden's accessory products add value to your liquid process and expand the application range of Wilden pumps by augmenting the performance and/or utility of the pump.

- **SD Equalizer** - designed to minimize pressure variation on the discharge end of the pump, allowing for a consistent laminar/streamline flow
- **Wil-Gard™** - detects and notifies plant personnel when a diaphragm has ruptured to prevent further damage to pump
- **Pump Cycle Monitor (PCMI)** - counts pump cycles by sensing the presence of the air valve spool
- **Drum Pump Kit** - enables Wilden 6 mm (1/4") and 13 mm (1/2") pumps to adapt directly to drums for cost-effective, efficient liquid transfer



Repair and Retrofit Kits

Wilden wet and air repair kits for AODD pumps have been designed to help properly maintain the health and performance of your Wilden pump.

Always use only authentic Wilden air kits and wet kits when repairing or maintaining your Wilden products to preserve optimal performance and factory warranties.

- Easily order online at your convenience
- Kits are maintained and shipped in sealed packaging
- Include all necessary components for repair and maintenance

Wilden also offers retrofit kits which allow you to upgrade your existing pumps. Other spare parts outside of the traditional repair kits are available upon request.





25 mm (1") PRO-FLO BOLTED METAL PUMP

DESIGNATION: THREADED (P220/A, P220/S, P220/W), FLANGED (P230/S)



Air Inlet: 1/4" FNPT
 Liquid Inlet: 25 mm (1")
 Liquid Discharge: 25 mm (1")
 Connection Type:
 NPT/BSPT (Threaded)
 DIN/ANSI (Flanged)

Max. Flow Rate:
 212 lpm (56 gpm)
 Max. Inlet Pressure:
 8.6 Bar (125 psig)
 Max. Size Solids:
 6.4 mm (1/4")

Max. Suction Lift:
 5.5 m Dry (18.2')
 9.3 m Wet (30.6')
 Shipping Weight:
 Aluminum 11 kg (24 lb)
 Ductile Iron 21 kg (47 lb)
 316 Stainless Steel 23 kg (51 lb)

P220/230

Dimensions

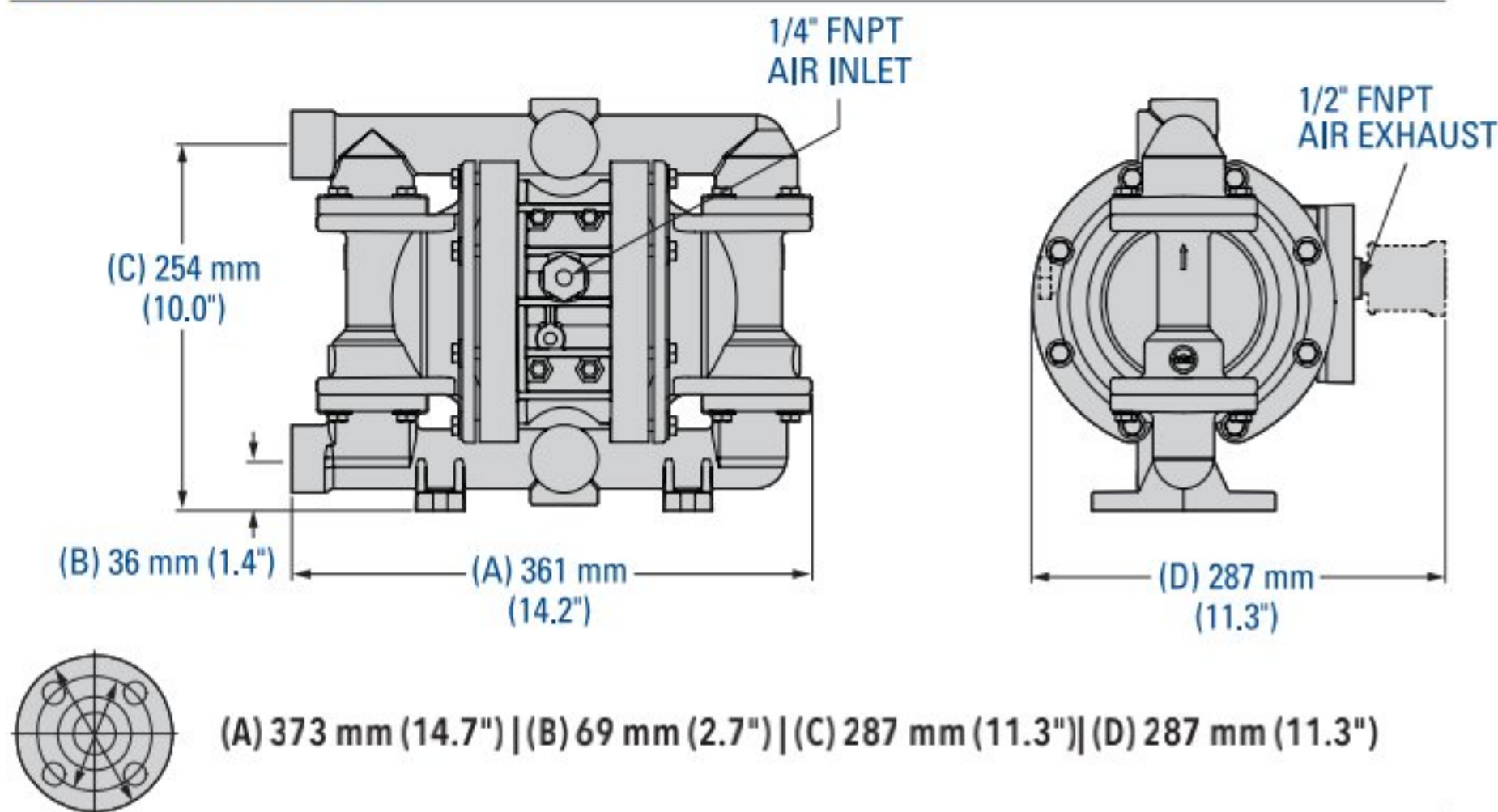

Note that dimensions vary by material and connection. For additional information, please refer to the P220/230 Metal EOM.

Flow Curve TPE-FITTED

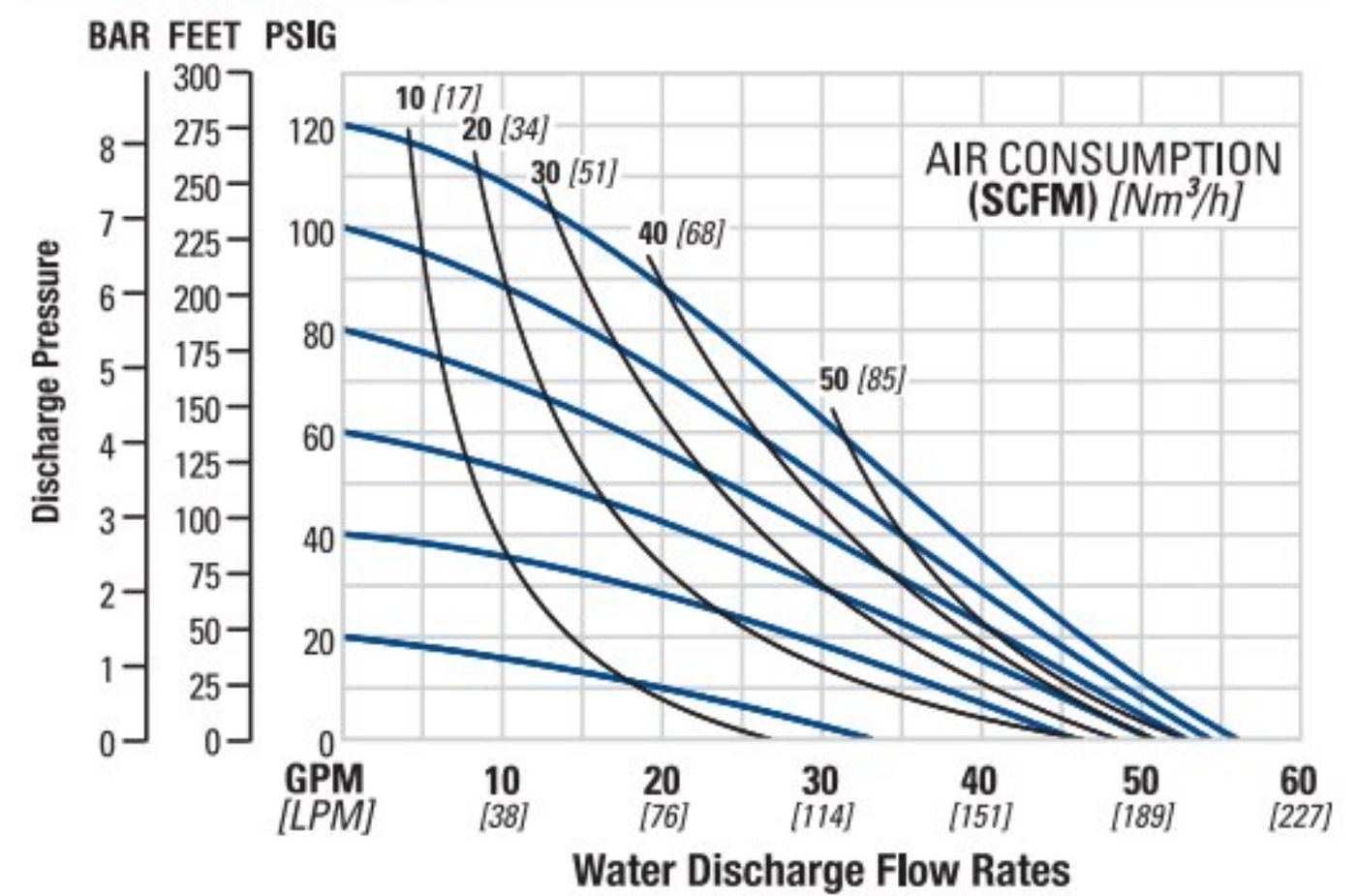

38 mm (1-1/2") PRO-FLO BOLTED METAL PUMP

DESIGNATION: THREADED (P420/A, P420/S, P420/W), FLANGED (P430/A, P430/S, P430/W)



Air Inlet: 1/2" FNPT
 Liquid Inlet: 38 mm (1-1/2")
 Liquid Discharge:
 38 mm (1-1/2")
 Connection Type:
 NPT/BSPT (Threaded)
 DIN/ANSI (Flanged)

Max. Flow Rate:
 492 lpm (130 gpm)
 Max. Inlet Pressure:
 8.6 bar (125 psig)
 Max. Size Solids:
 6.4 mm (1/4")

Max. Suction Lift:
 5.5 m Dry (18.2')
 9.0 m Wet (29.5')

Shipping Weight:
 420 Threaded AL 26 kg (57 lb)
 420 Threaded SS 50 kg (111 lb)
 420 Threaded Iron 39 kg (86 lb)
 430 Flanged AL 28 kg (62 lb)
 430 Flanged SS 53 kg (116 lb)
 430 Flanged Iron 42 kg (92 lb)

P420/430

Dimensions

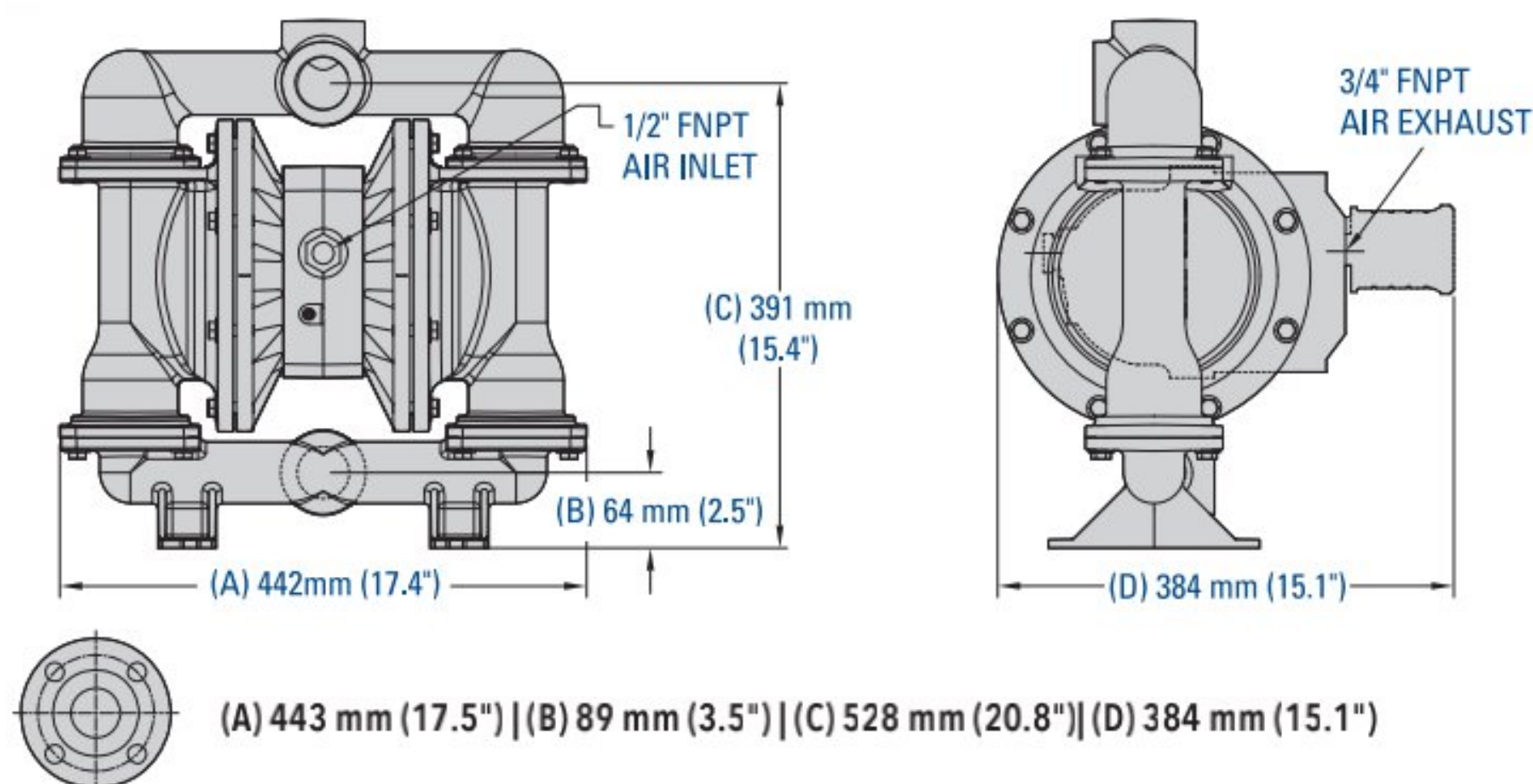

Note that dimensions vary by material and connection. For additional information, please refer to the P420/430 Metal EOM.

Flow Curve EZ-INSTALL TPE-FITTED

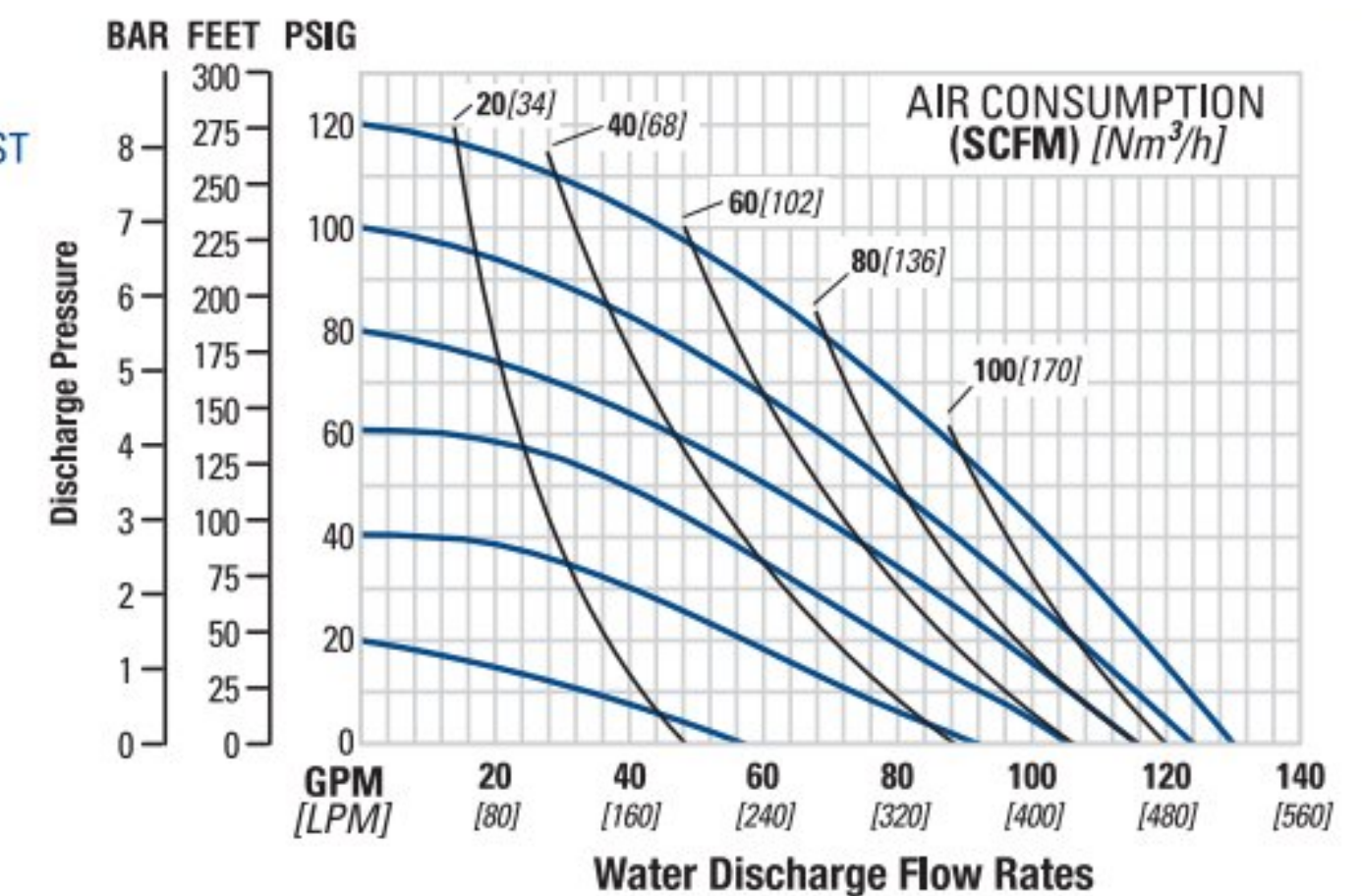



51 mm (2") PRO-FLO BOLTED METAL PUMP

DESIGNATION: THREADED (P820/A, P820/S, P820/W), FLANGED (P830/A, P830/S, P830/W)



Air Inlet: 1/2" FNPT

Liquid Inlet: 51 mm (2")

Liquid Discharge: 51 mm (2")

Connection Type:

NPT/BSPT (Threaded)

DIN/ANSI (Flanged)

Max. Flow Rate:

609 lpm (161 gpm)

Max. Inlet Pressure:

8.6 bar (125 psig)

Max. Size Solids:

6.4 mm (1/4")

Max. Suction Lift:

7.4 m Dry (24.3')

9.0 m Wet (29.5')

Shipping Weight:

820 Threaded AL 47 kg (104 lb)

820 Threaded SS 73 kg (161 lb)

820 Threaded Iron 71 kg (156 lb)

830 Flanged AL 54 kg (118 lb)

830 Flanged SS 81 kg (178 lb)

830 Flanged Iron 82 kg (181 lb)

P820/830

Dimensions

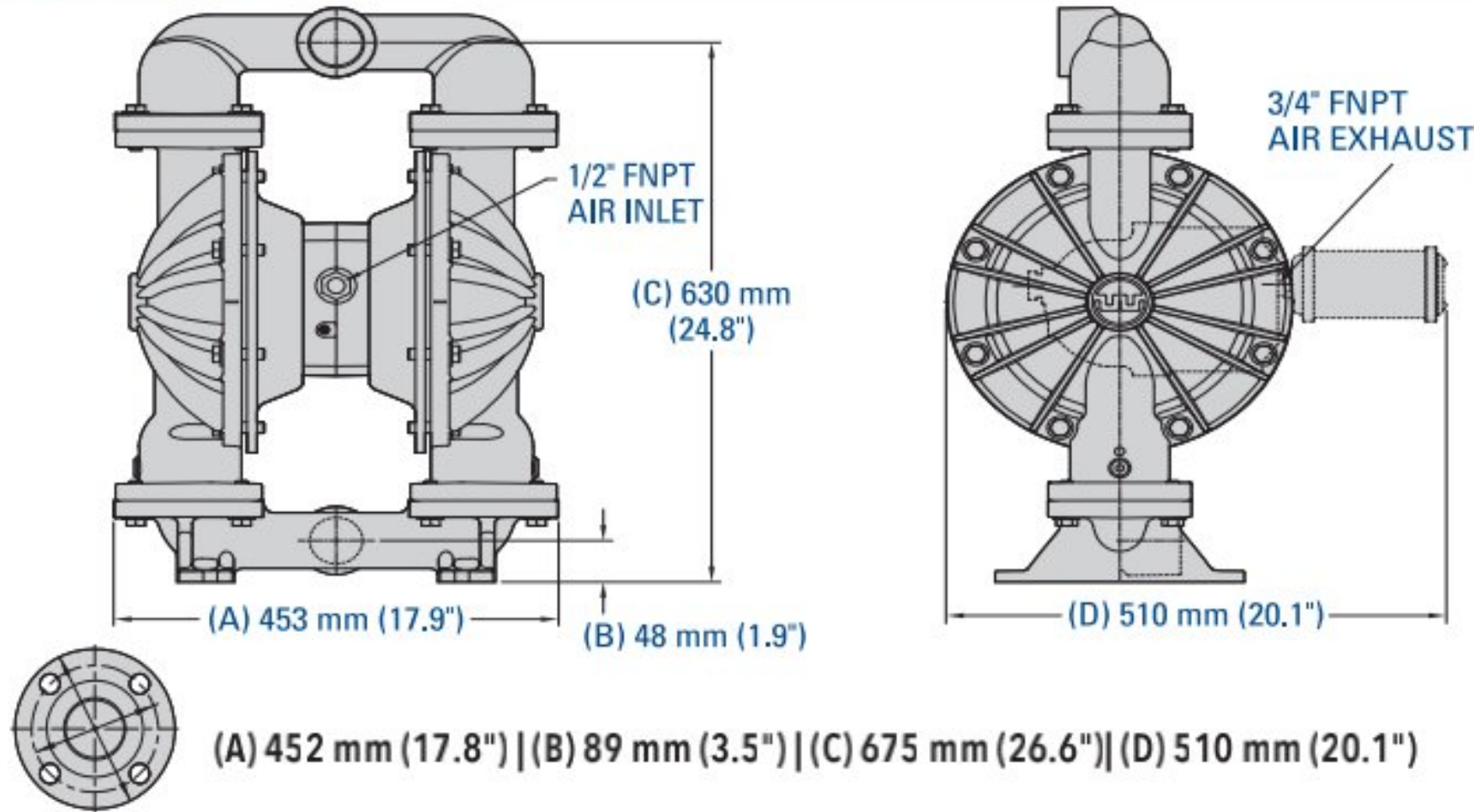

Note that dimensions vary by material and connection. For additional information, please refer to the P820/830 Metal EOM.

Flow Curve EZ-INSTALL TPE-FITTED

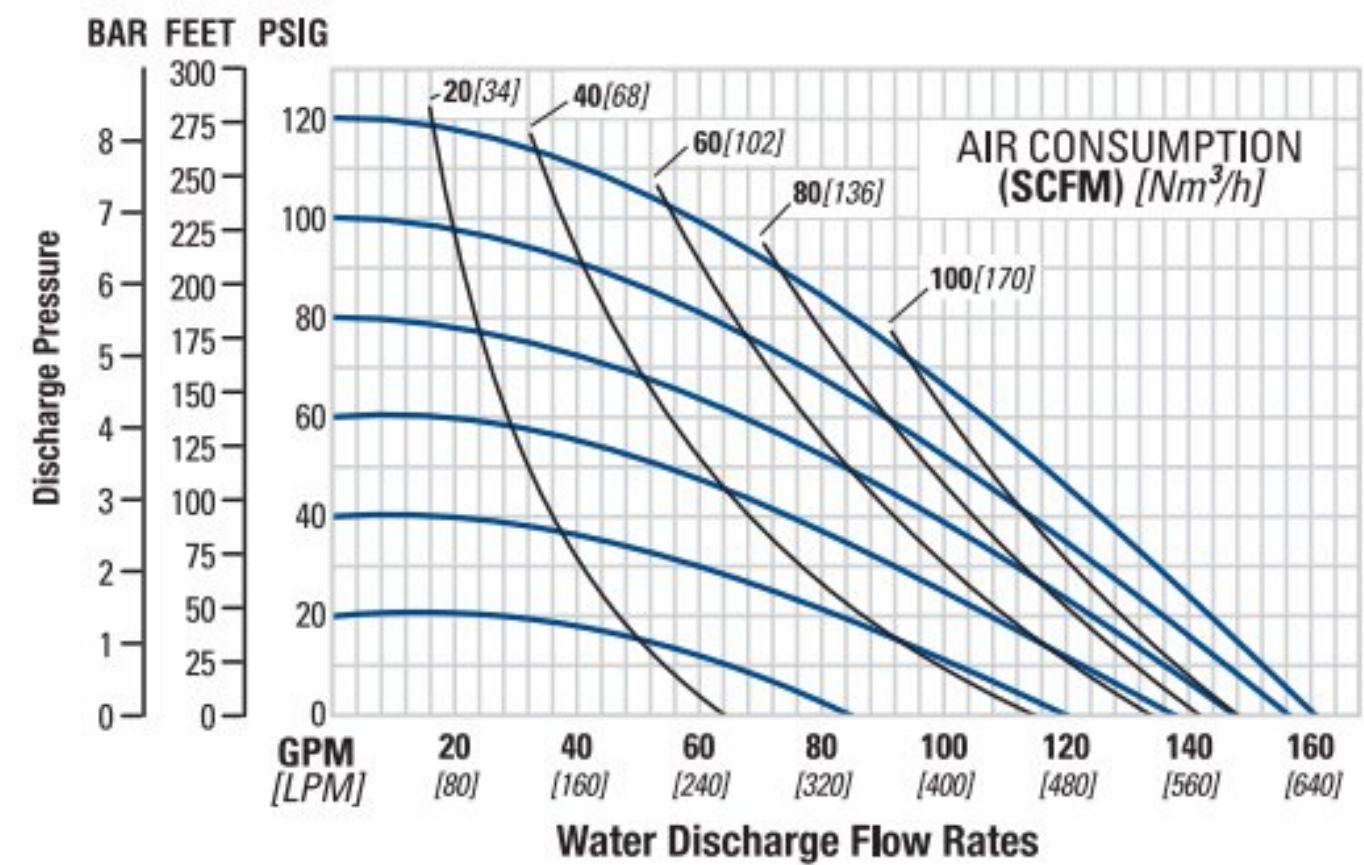

6 mm (1/4") PRO-FLO BOLTED PLASTIC PUMP

DESIGNATION: THREADED (P25/K, P25/P)



P25



Air Inlet: 1/8" FNPT

Liquid Inlet: 6 mm (1/4")

Liquid Discharge: 6 mm (1/4")

Connection Type:

NPT/BSPT (Threaded)

Max. Flow Rate:

16.7 lpm (4.4 gpm)

Max. Inlet Pressure:

8.6 bar (125 psig)

Max. Size Solids:

0.7 mm (1/32")

Max. Suction Lift:

1.9 m Dry (6.2')

9.3 m Wet (30.6')

Shipping Weight:

Polypropylene 2 kg (4 lb)

PVDF 2 kg (5 lb)

Dimensions

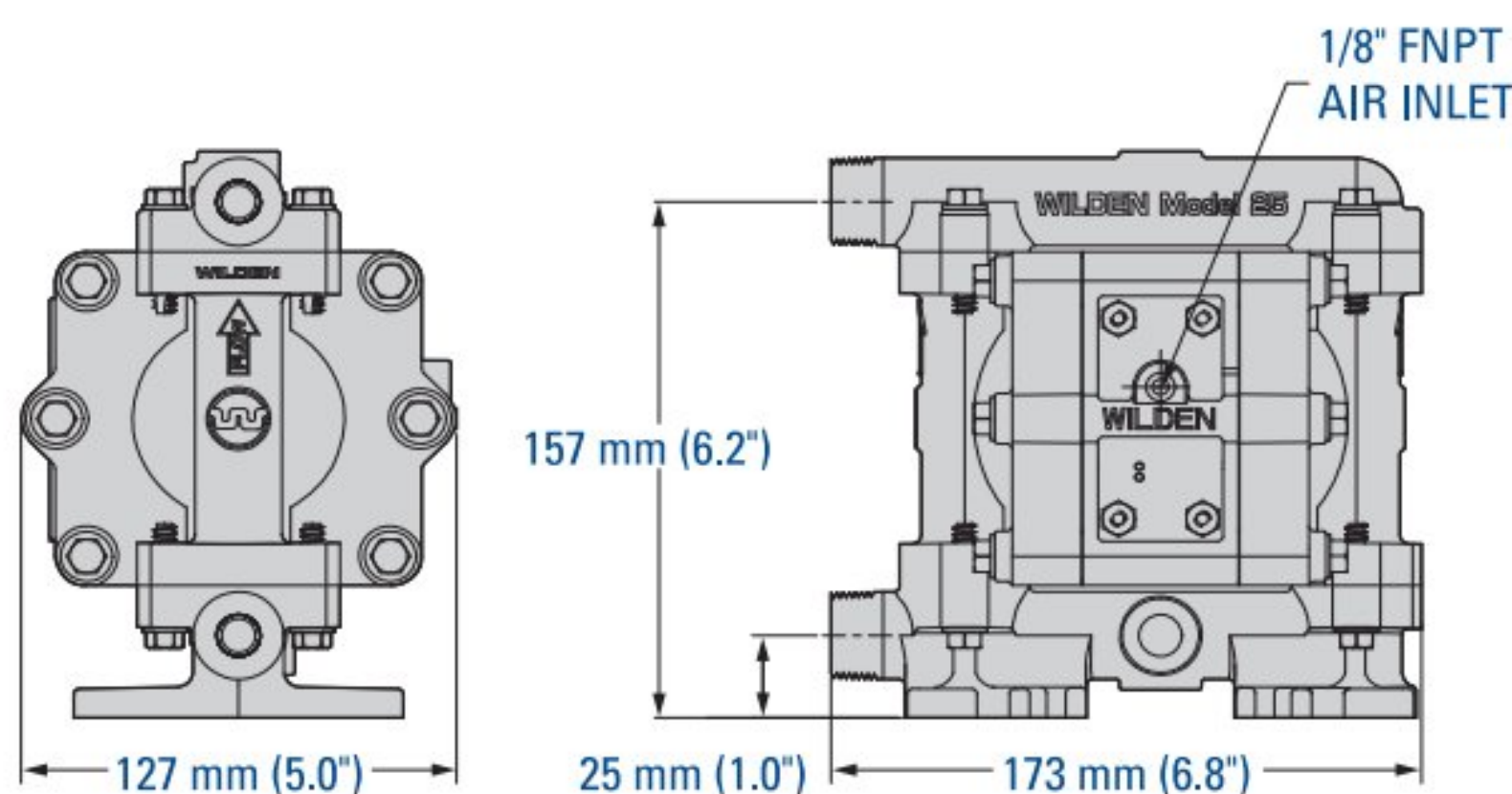

For additional information, please refer to the PP25 Plastic EOM.

Flow Curve PTFE-FITTED

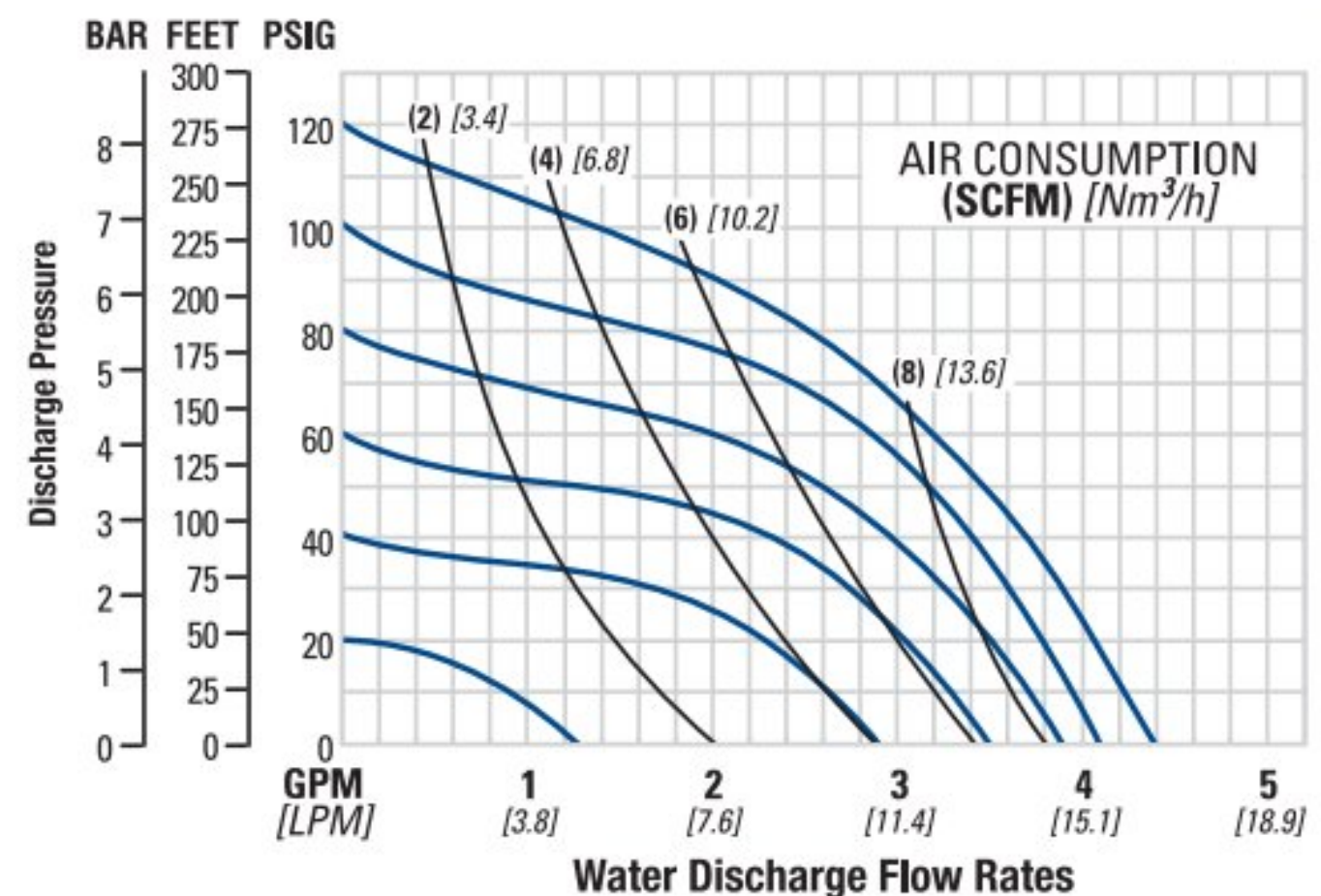



13 mm (1/2") PRO-FLO BOLTED PLASTIC PUMP

DESIGNATION: Threaded (P100/K, P100/P)



Air Inlet: 1/4" FNPT

Liquid Inlet: 13 mm (1/2")

Liquid Discharge: 13 mm (1/2")

Connection Type:

NPT/BSPT (Threaded)

Max. Flow Rate:

58.7 lpm (15.5 gpm)

Max. Inlet Pressure:

8.6 bar (125 psig)

Max. Size Solids:

1.6 mm (1/16")

Max. Suction Lift:

5.5 m Dry (17.0')

9.3 m Wet (30.6')

Shipping Weight:

Polypropylene 4 kg (8 lb)

PVDF 5 kg (10 lb)

P100

Dimensions

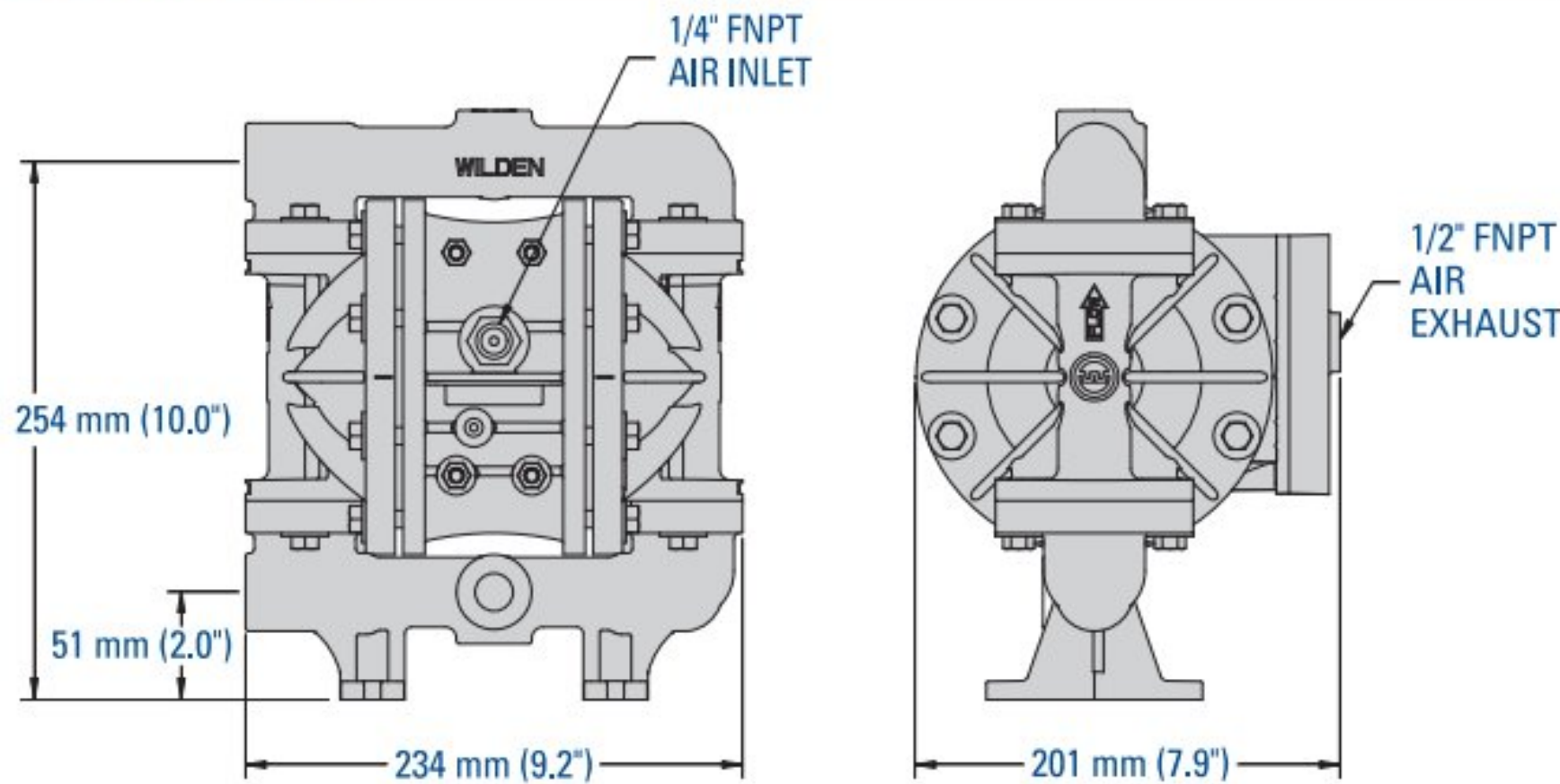

Flow Curve TPE-FITTED

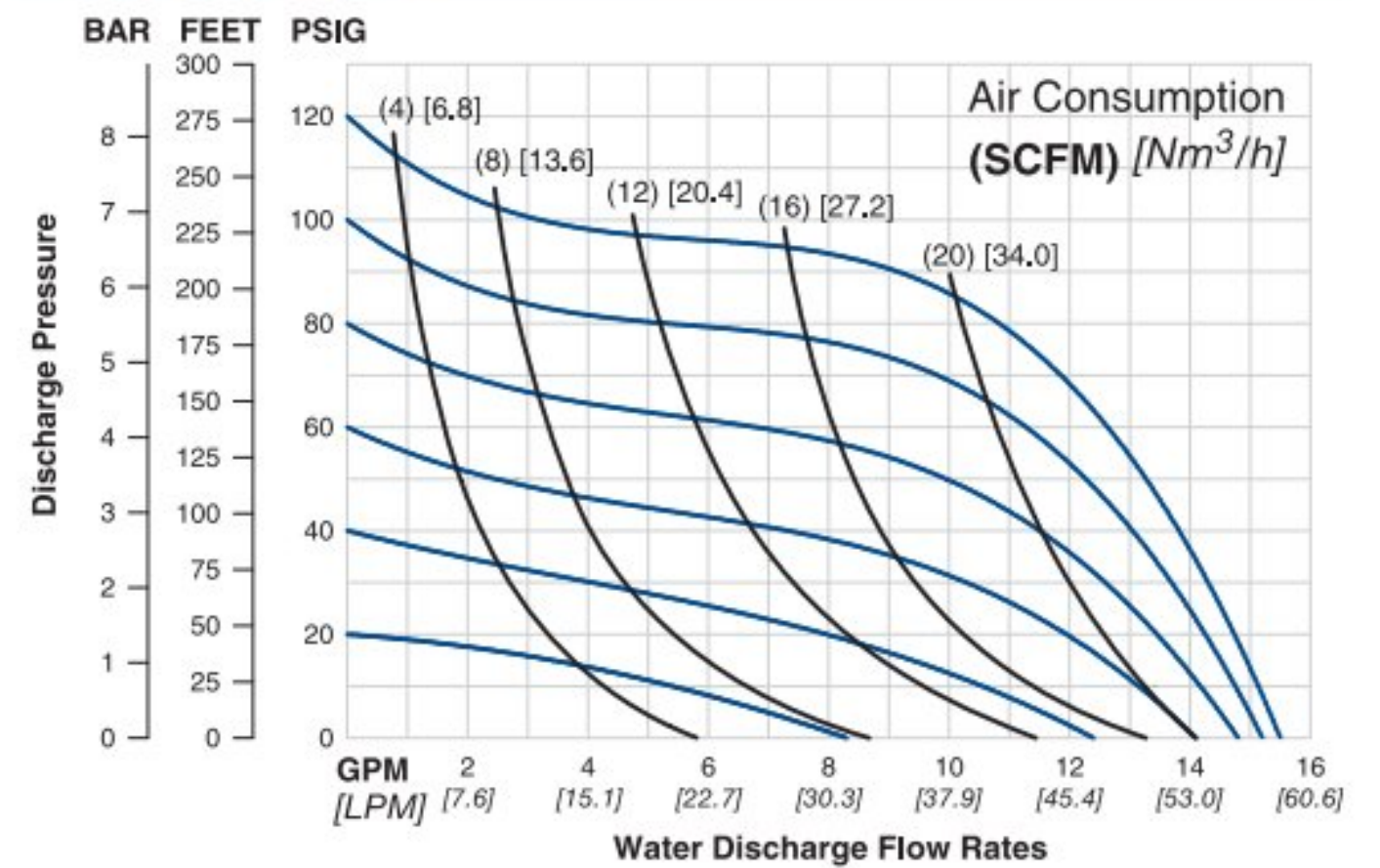

For additional information, please refer to the P100 Plastic EOM.

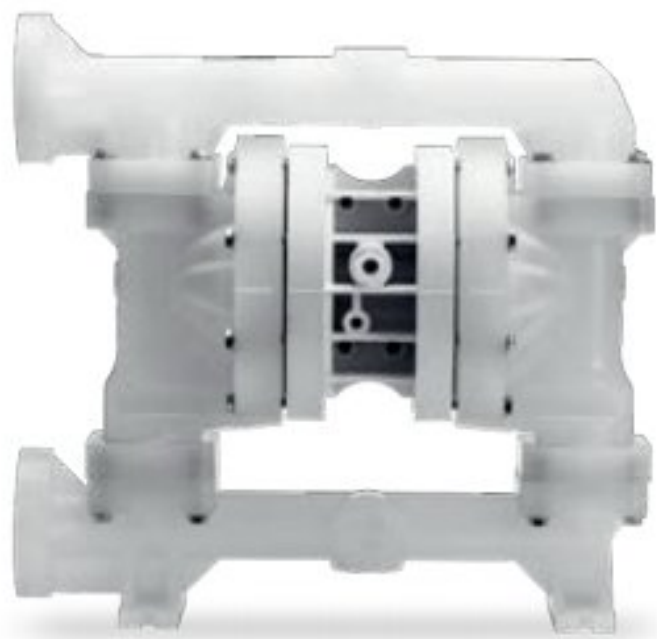

25 mm (1") PRO-FLO BOLTED PLASTIC PUMP

DESIGNATION: FLANGED (P200/K, P200/P)



Air Inlet: 1/4" FNPT

Liquid Inlet: 25 mm (1")

Liquid Discharge: 25 mm (1")

Connection Type:

DIN/ANSI (Flanged)

Max. Flow Rate:

220 lpm (58 gpm)

Max. Inlet Pressure:

8.6 bar (125 psig)

Max. Size Solids:

4.76 mm (3/16")

Max. Suction Lift:

3.6 m Dry (11.9')

9.8 m Wet (32.0')

Shipping Weight:

Polypropylene 10 kg (22 lb)

PVDF 15 kg (32 lb)

P200

Dimensions

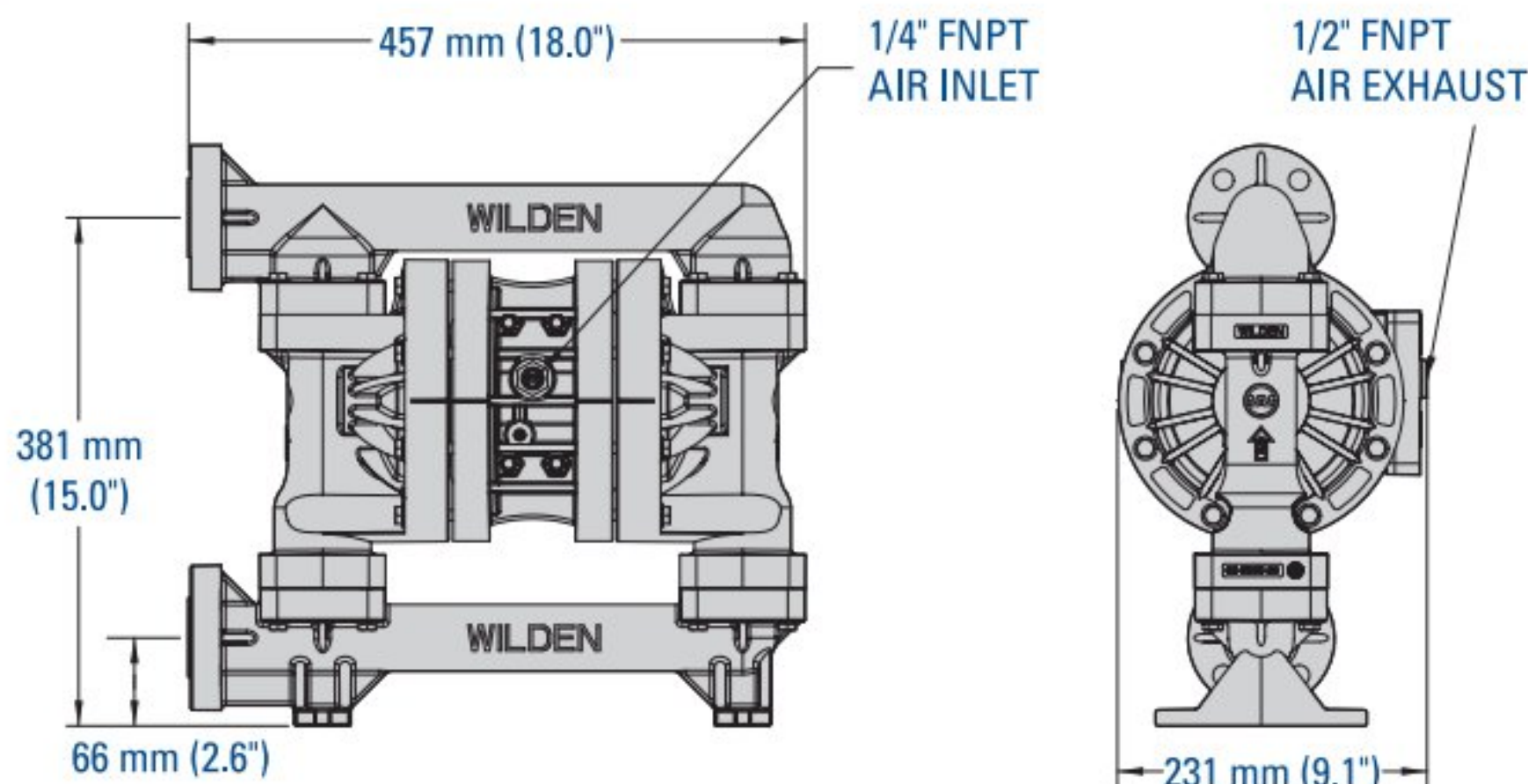

Flow Curve TPE-FITTED

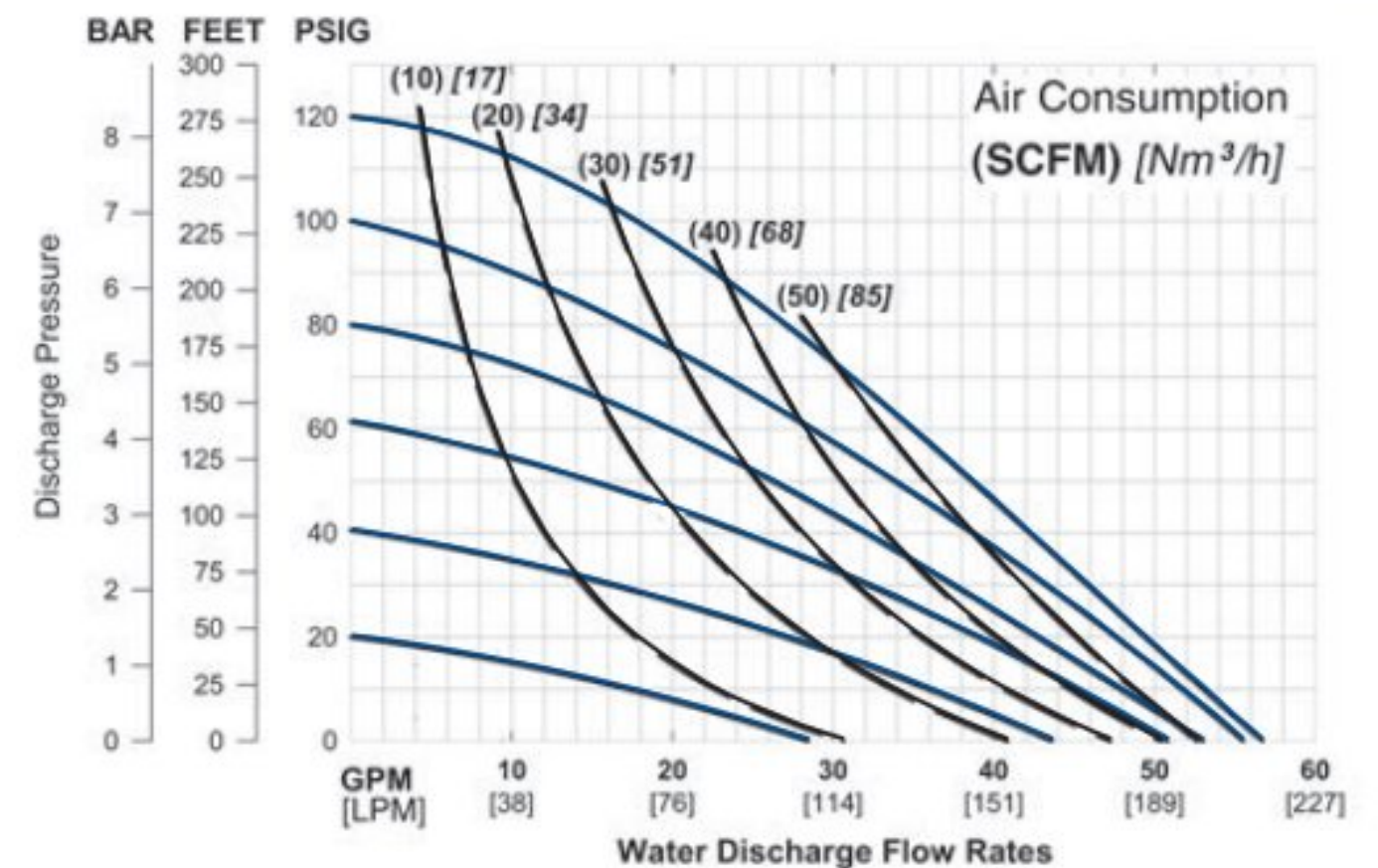

For additional information, please refer to the P200 Plastic EOM.

38 mm (1-1/2") PRO-FLO BOLTED PLASTIC PUMP

DESIGNATION: FLANGED (P400/K, P400/P)



P400

Air Inlet: 1/2" FNPT
 Liquid Inlet: 38 mm (1-1/2")
 Liquid Discharge: 38 mm (1-1/2")
 Connection Type:
 DIN/ANSI (Flanged)

Max. Flow Rate:
 454 lpm (120 gpm)
 Max. Inlet Pressure:
 8.6 bar (125 psig)
 Max. Size Solids:
 6.4 mm (1/4")

Max. Suction Lift:
 5.7 m Dry (18.7')
 9.7 m Wet (31.8')
 Shipping Weight:
 Polypropylene 19 kg (41 lb)
 PVDF 27 kg (59 lb)

Dimensions

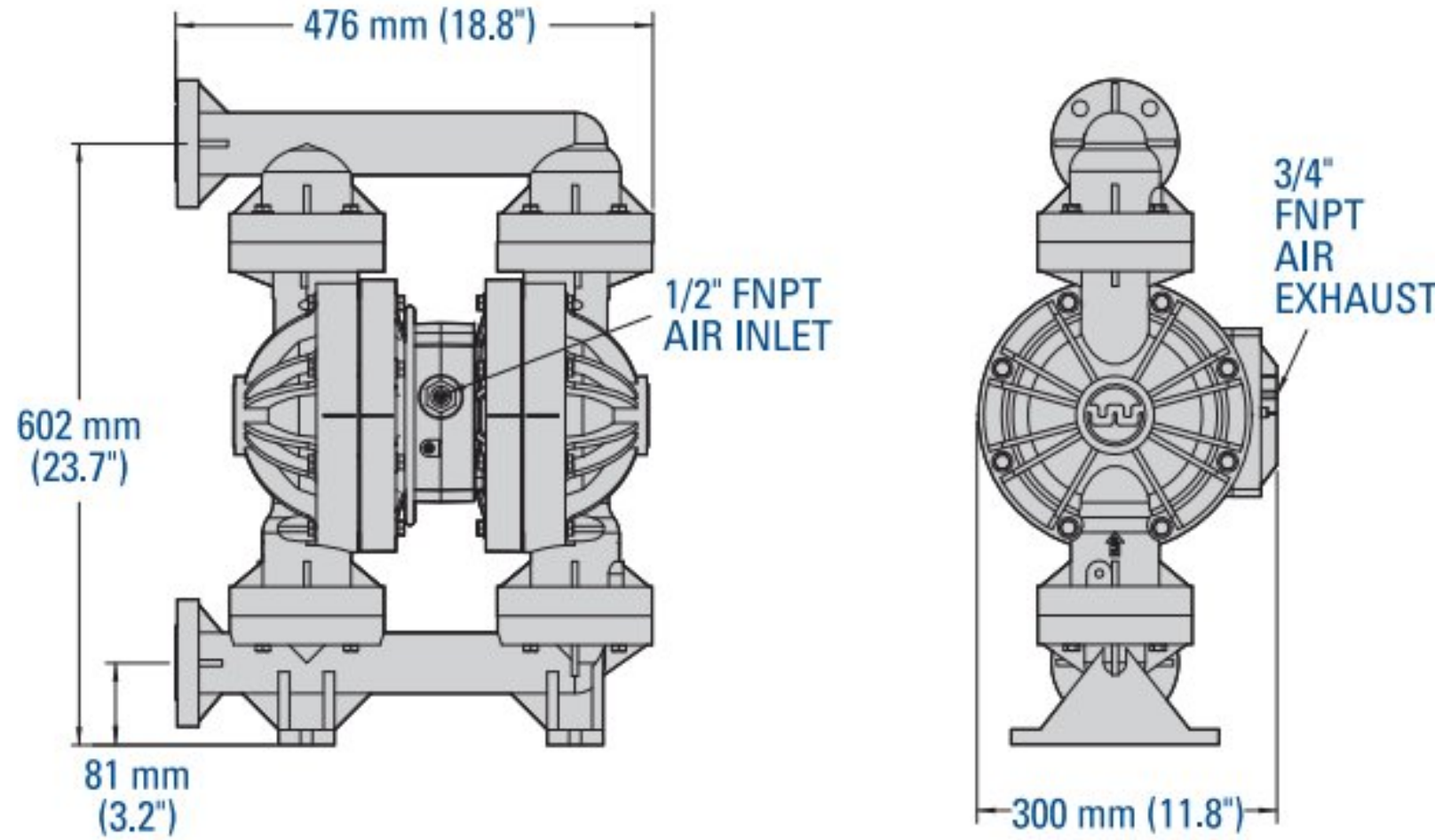

Note that dimensions vary by material and connection. For additional information, please refer to the P400 Plastic EOM.

Flow Curve TPE-FITTED

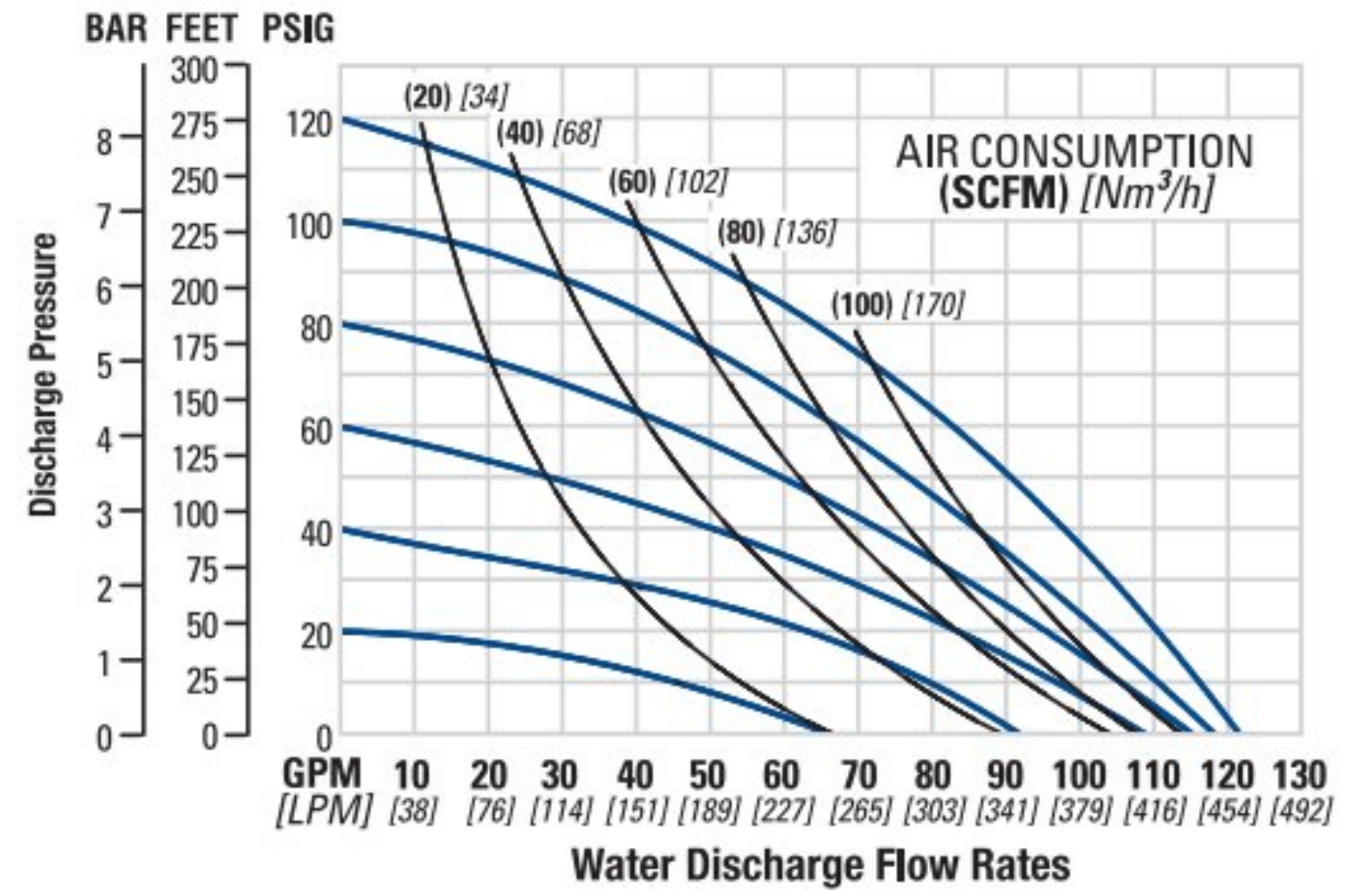

51 mm (2") PRO-FLO BOLTED PLASTIC PUMP

DESIGNATION: Flanged (P800/K, P800/P)

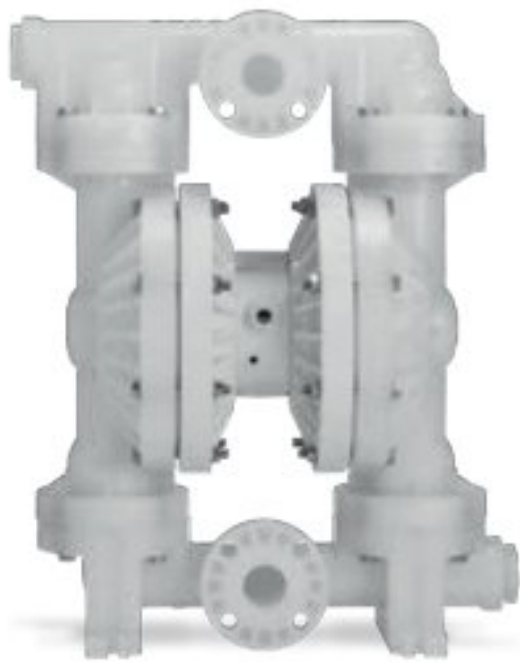

P800

Air Inlet: 1/2" FNPT
 Liquid Inlet: 51 mm (2")
 Liquid Discharge: 51 mm (2")
 Connection Type:
 DIN/ANSI (Flanged)

Max. Flow Rate:
 624 lpm (165 gpm)
 Max. Inlet Pressure:
 8.6 bar (125 psig)
 Max. Size Solids:
 6.4 mm (1/4")

Max. Suction Lift:
 6.2 m Dry (20.4')
 9.0 m Wet (29.5')
 Shipping Weight:
 Polypropylene 32kg (70 lb)
 PVDF 45 kg (99 lb)

Dimensions

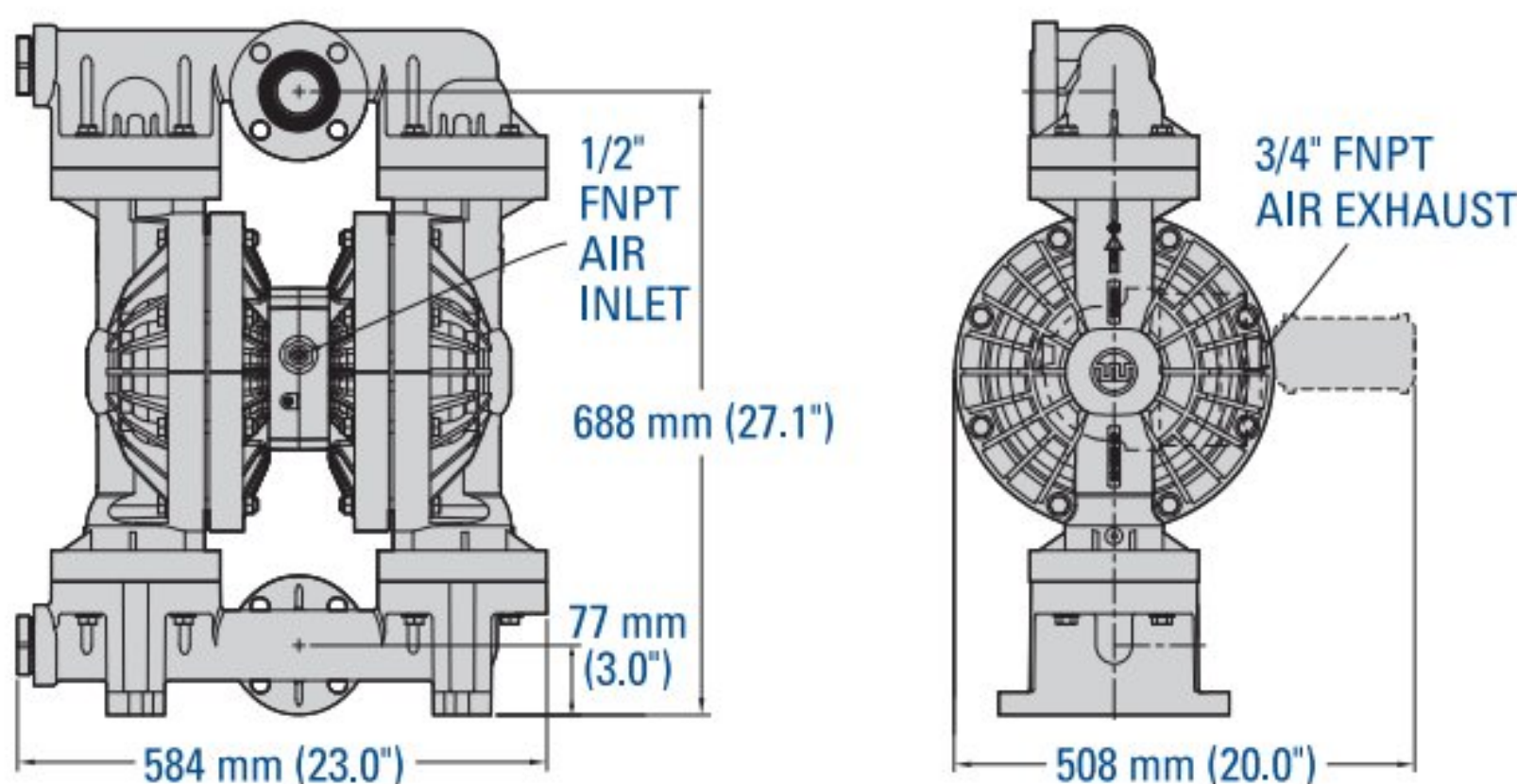

Note that dimensions vary by material and connection. For additional information, please refer to the P800 Plastic EOM.

Flow Curve TPE-FITTED

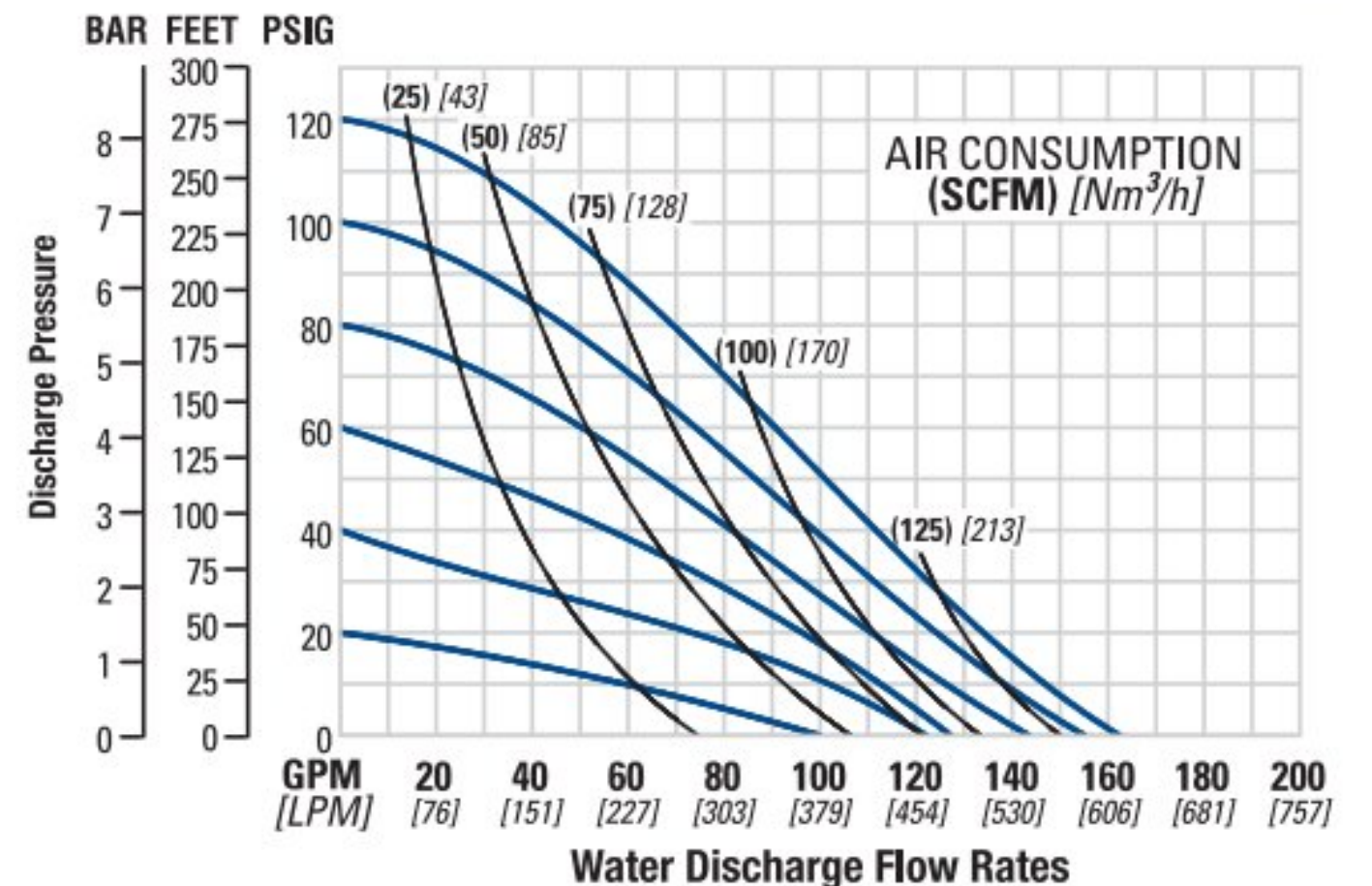



P1500

76 mm (3") PRO-FLO BOLTED PLASTIC PUMP

DESIGNATION: FLANGED (P1500/K, P1500/P)



Air Inlet: 3/4" FNPT

Liquid Inlet: 76 mm (3")

Liquid Discharge: 76 mm (3")

Connection Type:

DIN/ANSI (Flanged)

Max. Flow Rate:

878 lpm (232 gpm)

Max. Inlet Pressure:

8.6 bar (125 psig) (PVDF only)

6.9 bar (100 psig) (Polypropylene only)

Max. Size Solids:

12.7 mm (1/2")

Max. Suction Lift:

5.5 m Dry (18.2')

8.6 m Wet (28.4')

Shipping Weight:

Polypropylene 138 kg (305 lb)

PVDF 161 kg (356 lb)

Dimensions

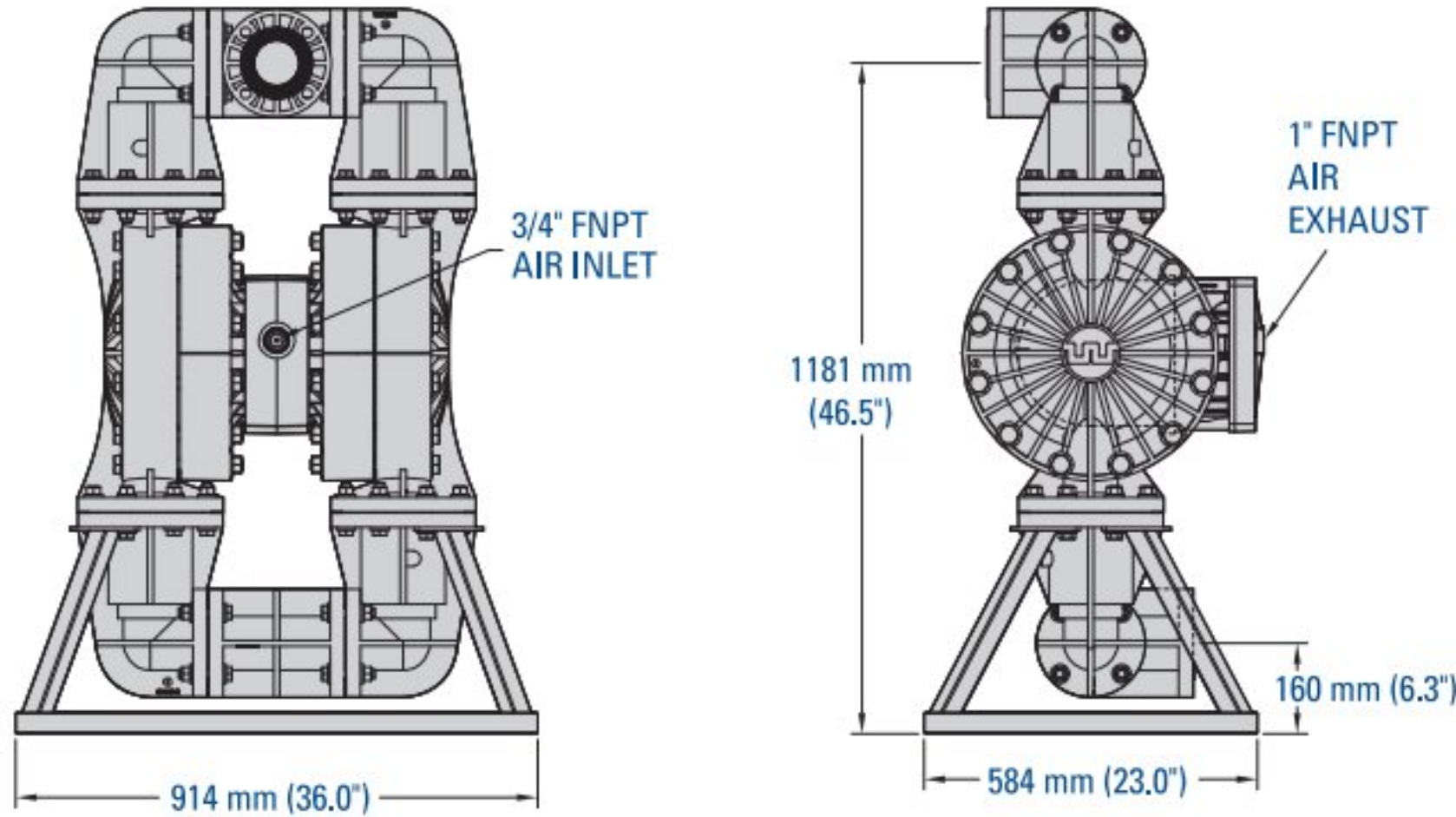

Note that dimensions vary by material and connection. For additional information, please refer to the P1500 Plastic EOM.

Flow Curve FULL-STROKE PTFE-FITTED

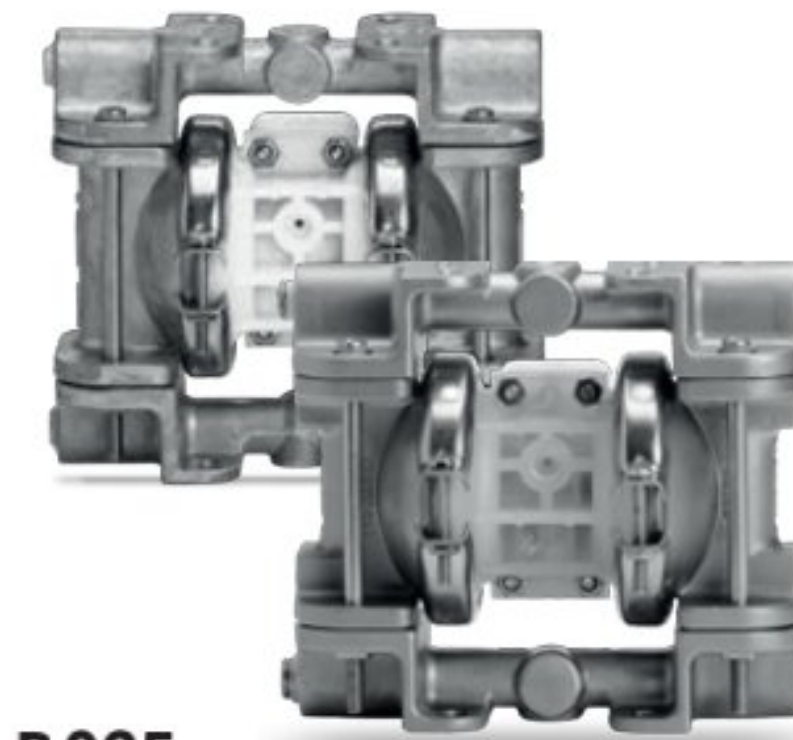
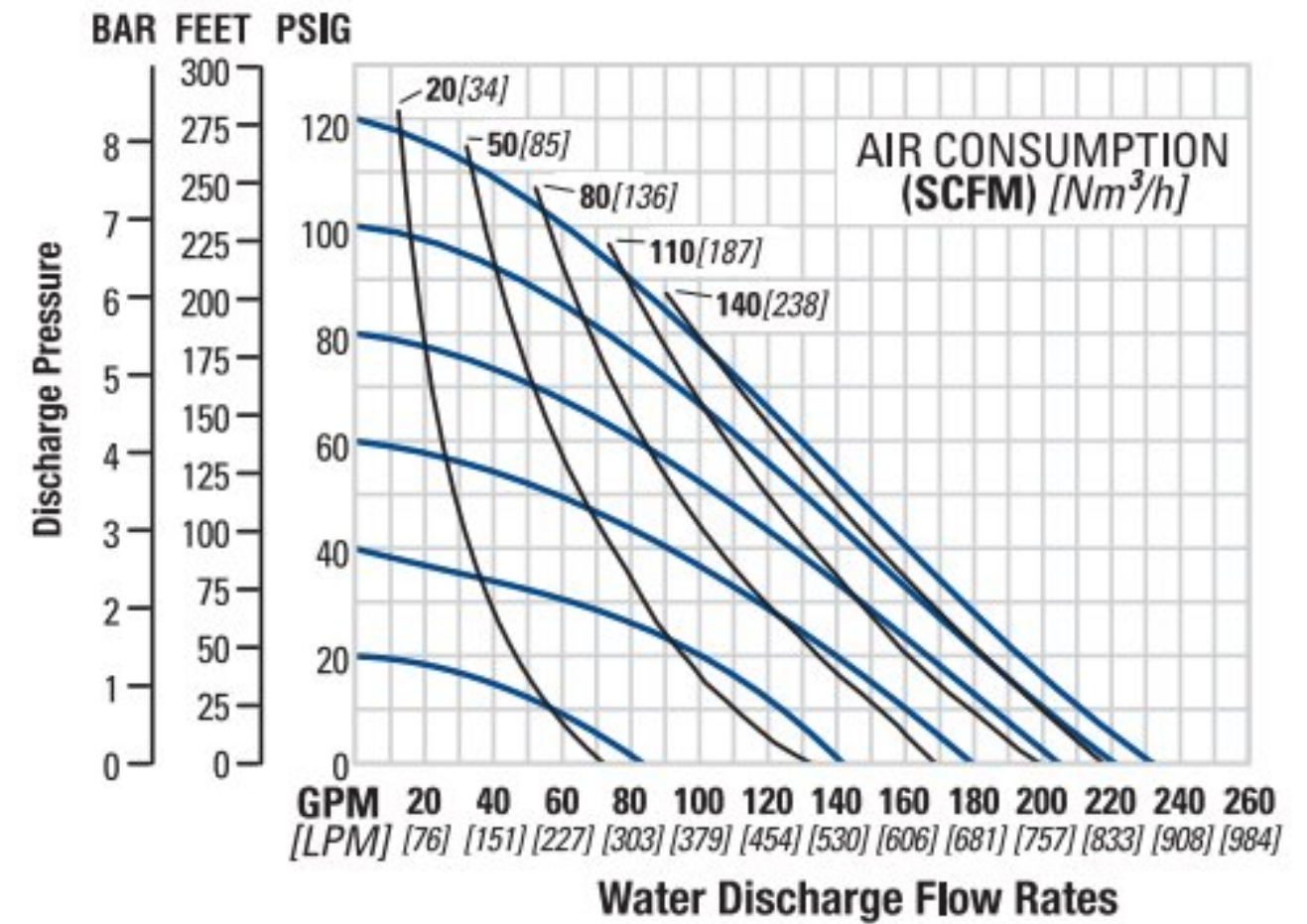

P.025

6 mm (1/4") PRO-FLO CLAMPED METAL PUMP

DESIGNATION: THREADED (P.025/A, P.025/S)



Air Inlet: 1/8" FNPT

Liquid Inlet: 6 mm (1/4")

Liquid Discharge: 6 mm (1/4")

Connection Type:

NPT/BSPT (Threaded)

Max. Flow Rate:

18.9 lpm (5 gpm)

Max. Inlet Pressure:

8.6 bar (125 psig)

Max. Size Solids:

0.4 mm (1/64")

Max. Suction Lift:

3.3 m Dry (10.8')

9.5 m Wet (31.2')

Shipping Weight:

Aluminum 1.8 kg (4 lb)

Stainless Steel 4.0 kg (8.9 lb)

Hastelloy® 4.3 kg (9.5 lb)

Dimensions

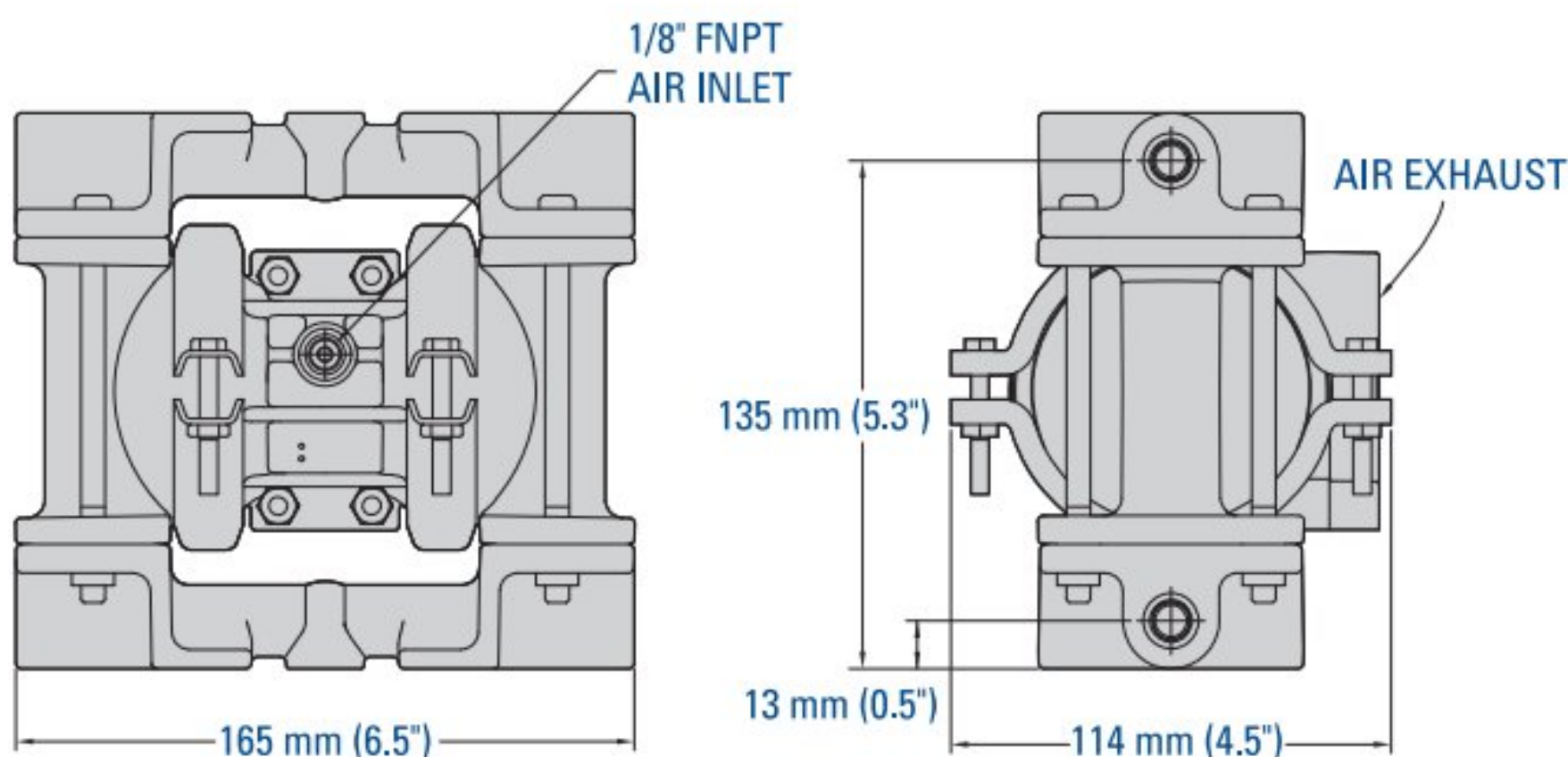

Flow Curve TPE-FITTED

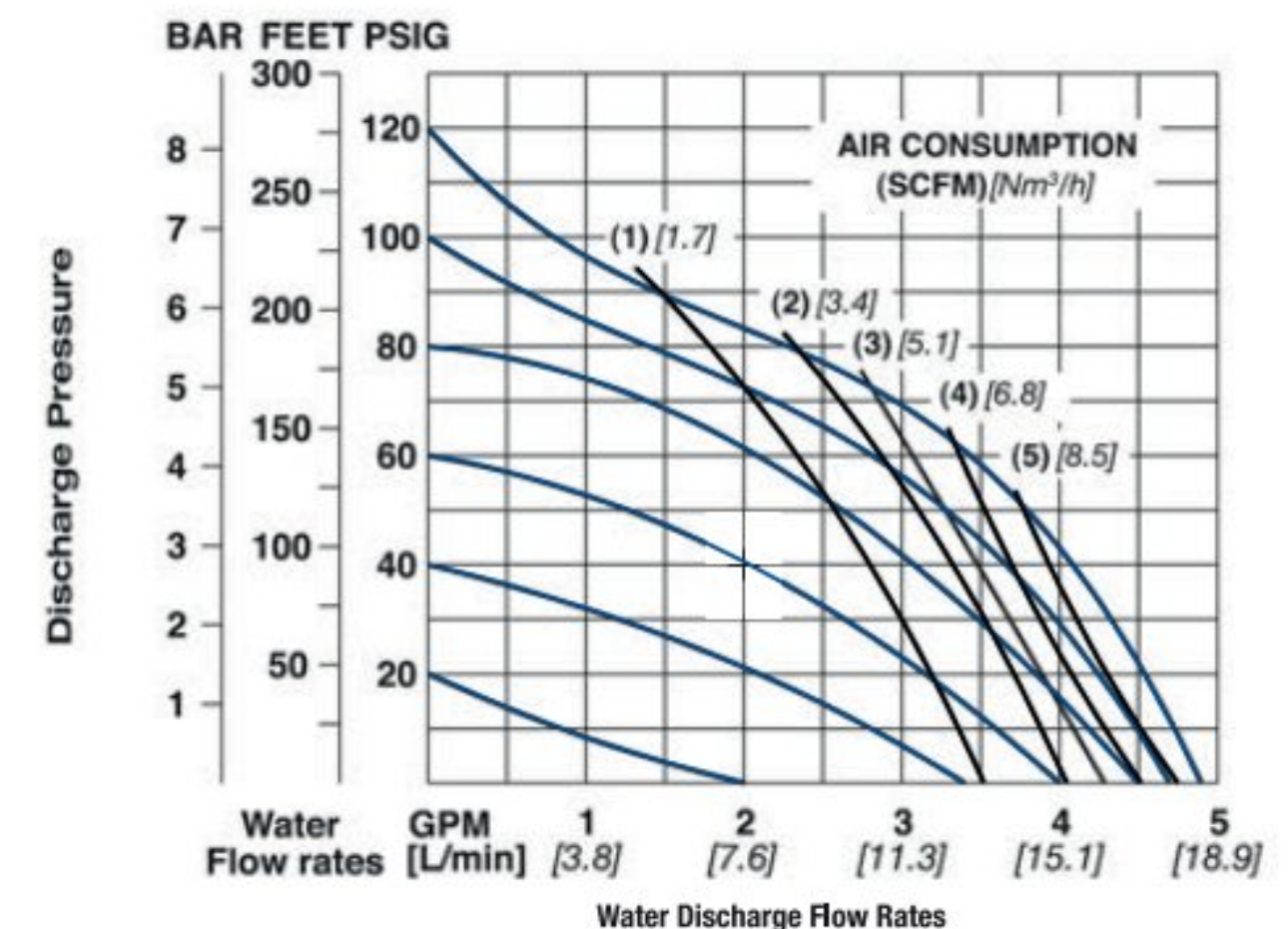

For additional information, please refer to the P.025 Metal EOM.

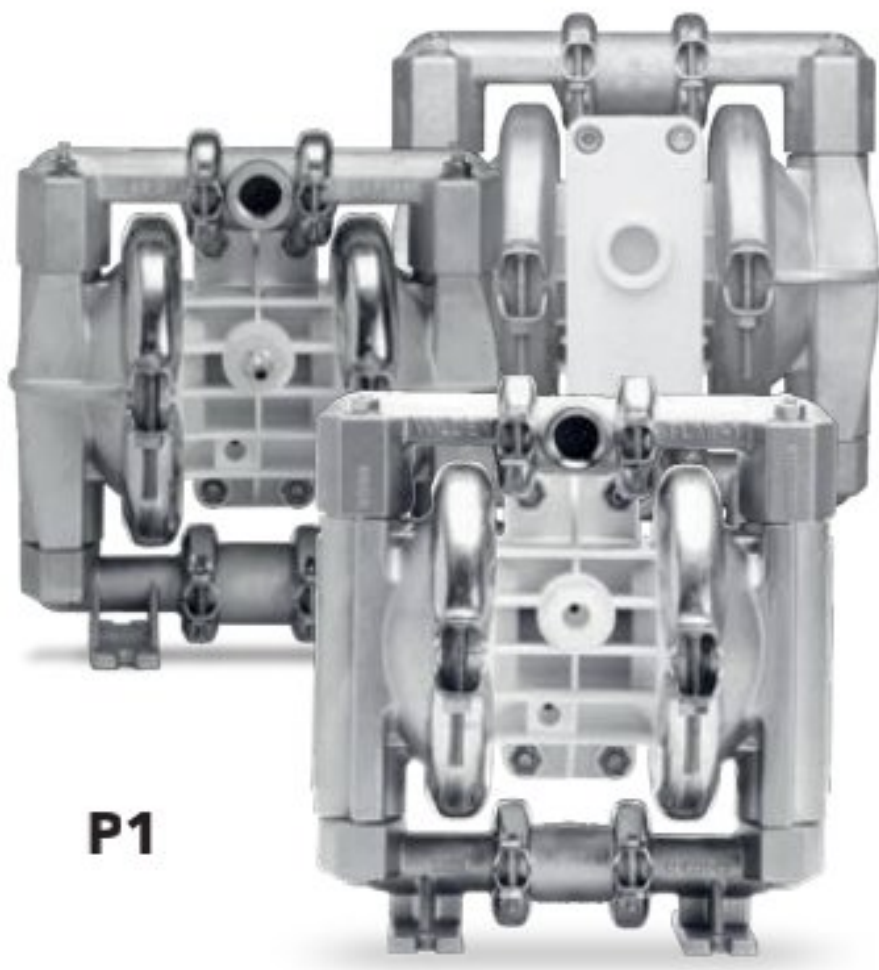

P1

13 mm (1/2") PRO-FLO CLAMPED METAL PUMP

DESIGNATION: THREADED (P1/A, P1/S)



Air Inlet: 1/4" FNPT

Liquid Inlet: 13 mm (1/2")

Liquid Discharge: 13 mm (1/2")

Connection Type:

NPT/BSPT (Threaded)

Max. Flow Rate:

58.7 lpm (15.5 gpm)

Max. Inlet Pressure:

8.6 bar (125 psig)

Max. Size Solids:

1.59 mm (1/16")

Max. Suction Lift:

5.8 m Dry (19.0')

9.5 m Wet (31.0')

Shipping Weight:

Aluminum 6 kg (13 lb)

Stainless Steel 9kg (20 lb)

Dimensions

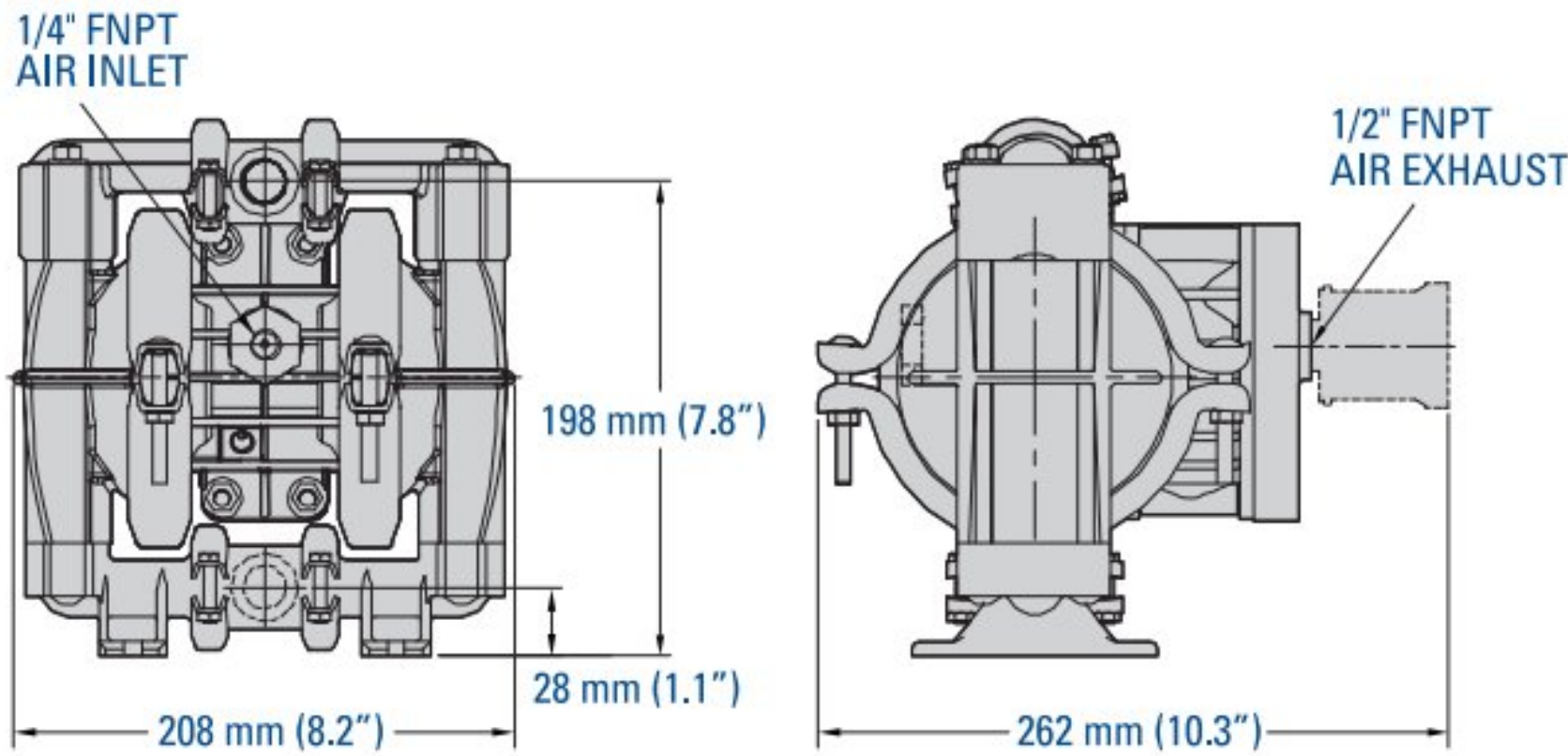

Flow Curve TPE-FITTED

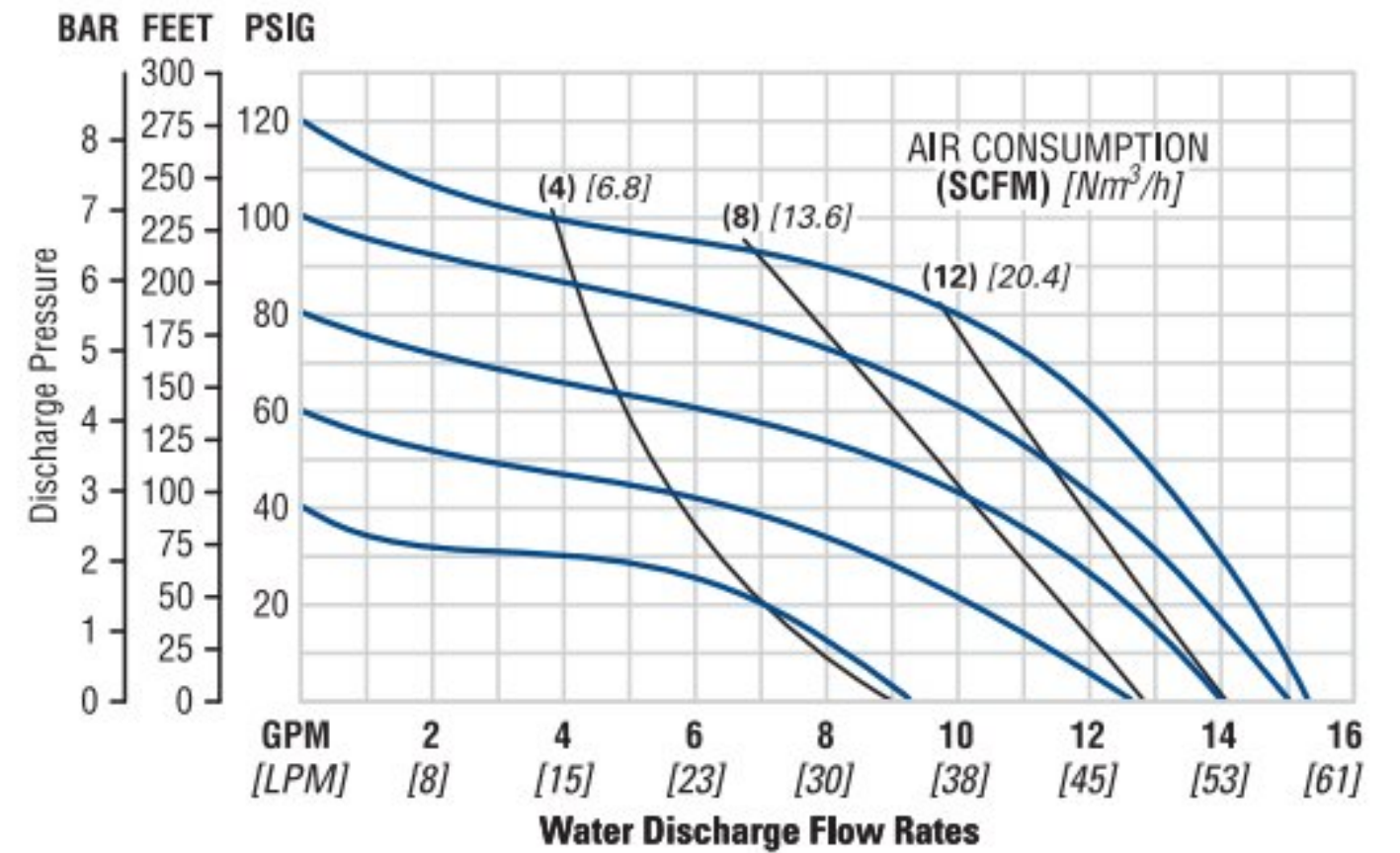

Note that dimensions vary by material and connection. For additional information, please refer to the P1 Metal EOM.



P2

25 mm (1") PRO-FLO CLAMPED METAL PUMP

DESIGNATION: THREADED (P2/A, P2/S)



Air Inlet: 1/4" FNPT

Liquid Inlet: 25 mm (1")

Liquid Discharge: 19 mm (3/4")

Connection Type:

NPT/BSPT (Threaded)

Max. Flow Rate:

172 lpm (45.5 gpm)

Max. Inlet Pressure:

8.6 bar (125 psig)

Max. Size Solids:

3.2 mm (1/8")

Max. Suction Lift:

7.6 m Dry (25.0')

9.0 m Wet (29.5')

Shipping Weight:

Aluminum 9 kg (20 lb)

Stainless Steel 17 kg (37 lb)

Dimensions

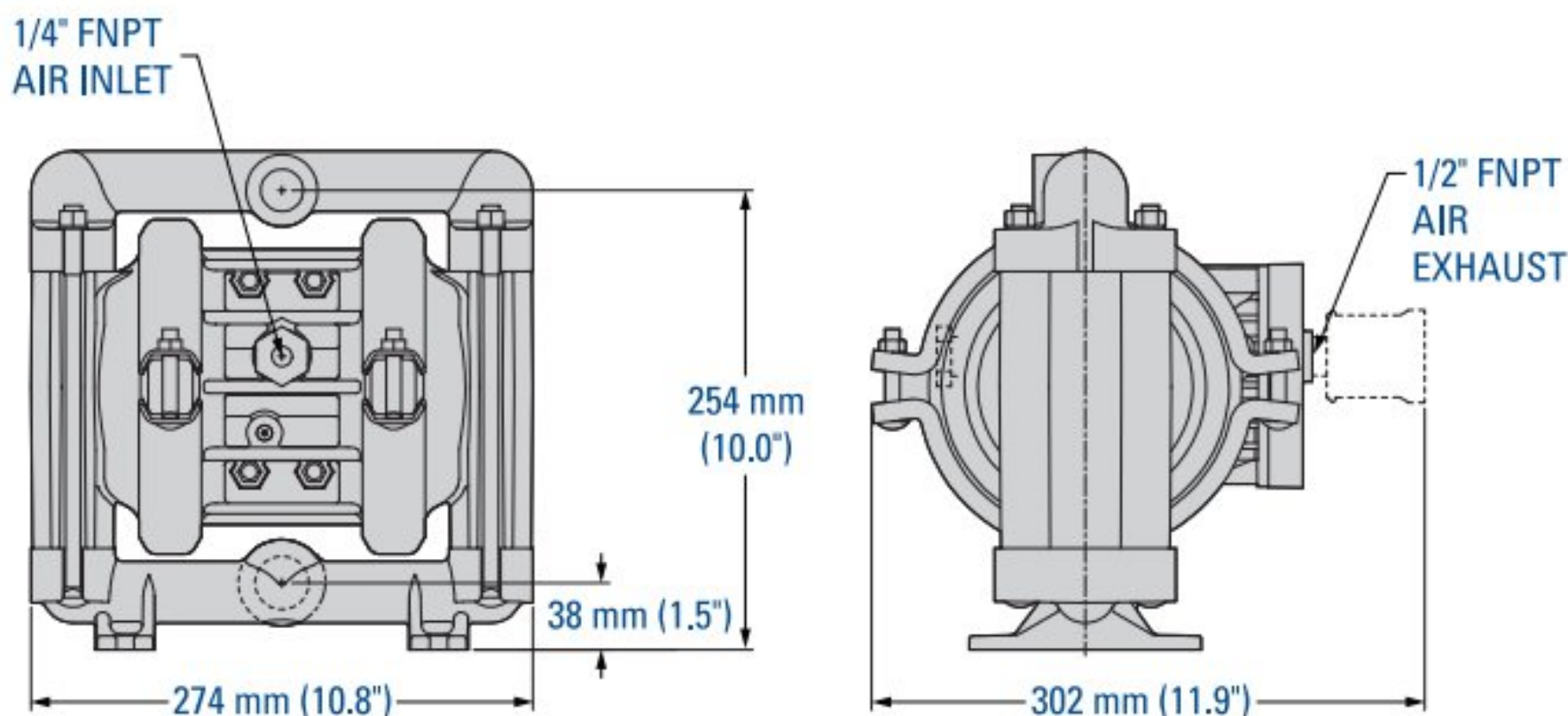

Flow Curve TPE-FITTED

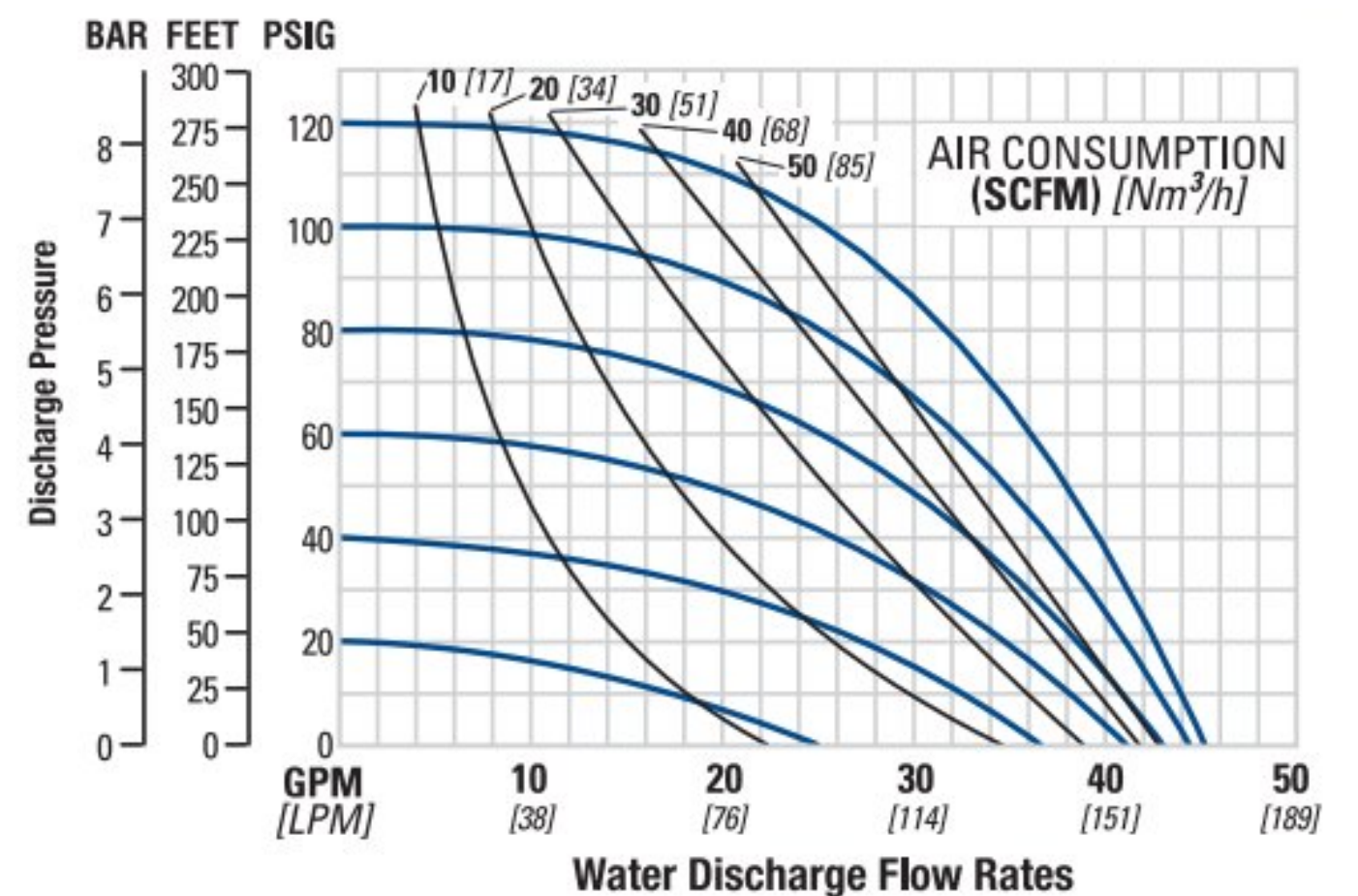

For additional information, please refer to the P2 Metal EOM.

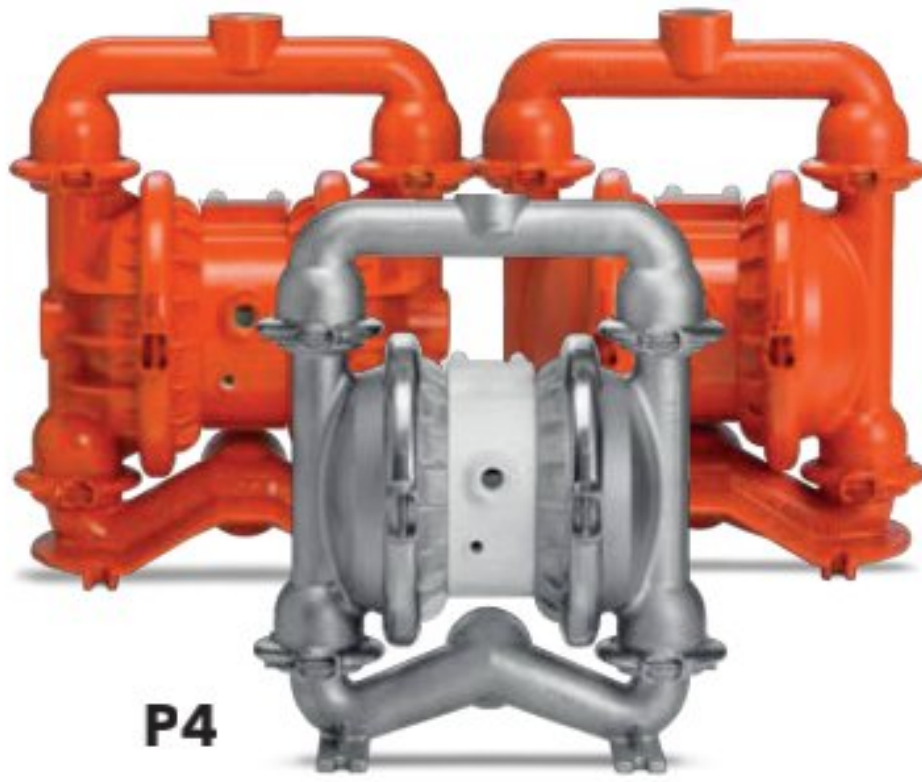

P4

38 mm (1-1/2") PRO-FLO CLAMPED METAL PUMP

DESIGNATION: THREADED (P4/A, P4/S, P4/W)



Air Inlet: 1/2" FNPT
 Liquid Inlet: 38 mm (1-1/2")
 Liquid Discharge: 32 mm (1-1/4")
 Connection Type:
 NPT/BSPT (Threaded)

Max. Flow Rate:
 330 lpm (87.2 gpm)
 Max. Inlet Pressure:
 8.6 bar (125 psig)
 Max. Size Solids:
 4.8 mm (3/16")

Max. Suction Lift:
 6.4 m Dry (21.0')
 9.3 m Wet (30.6')
 Shipping Weight:
 Aluminum 13 kg (29 lb)
 316 Stainless Steel 20 kg (45 lb)
 Cast Iron 22 kg (49 lb)
 Alloy C 23 kg (51 lb)

Dimensions

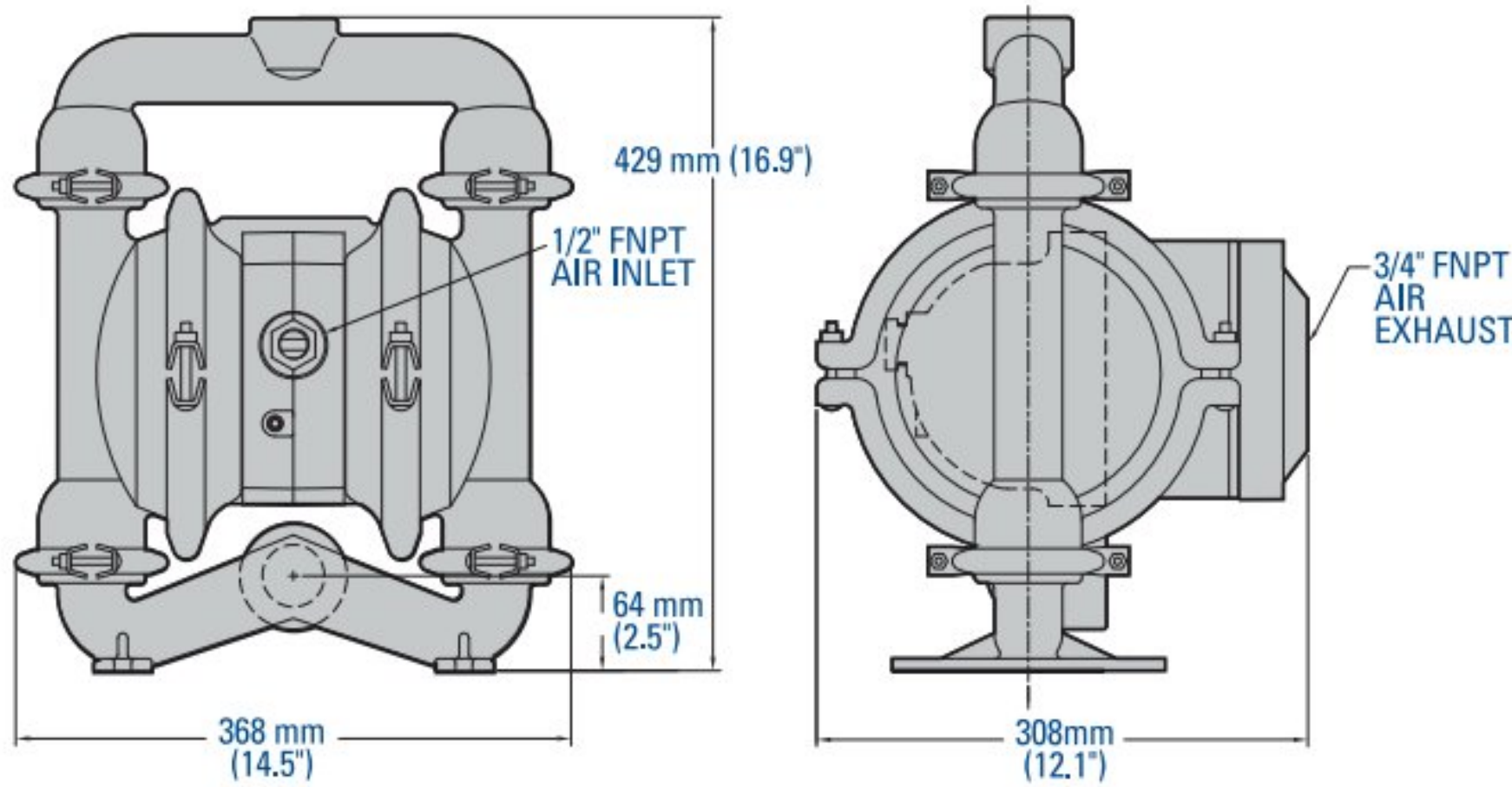

Note that dimensions vary by material. For additional information, please refer to the P4 Metal EOM.

Flow Curve TPE-FITTED

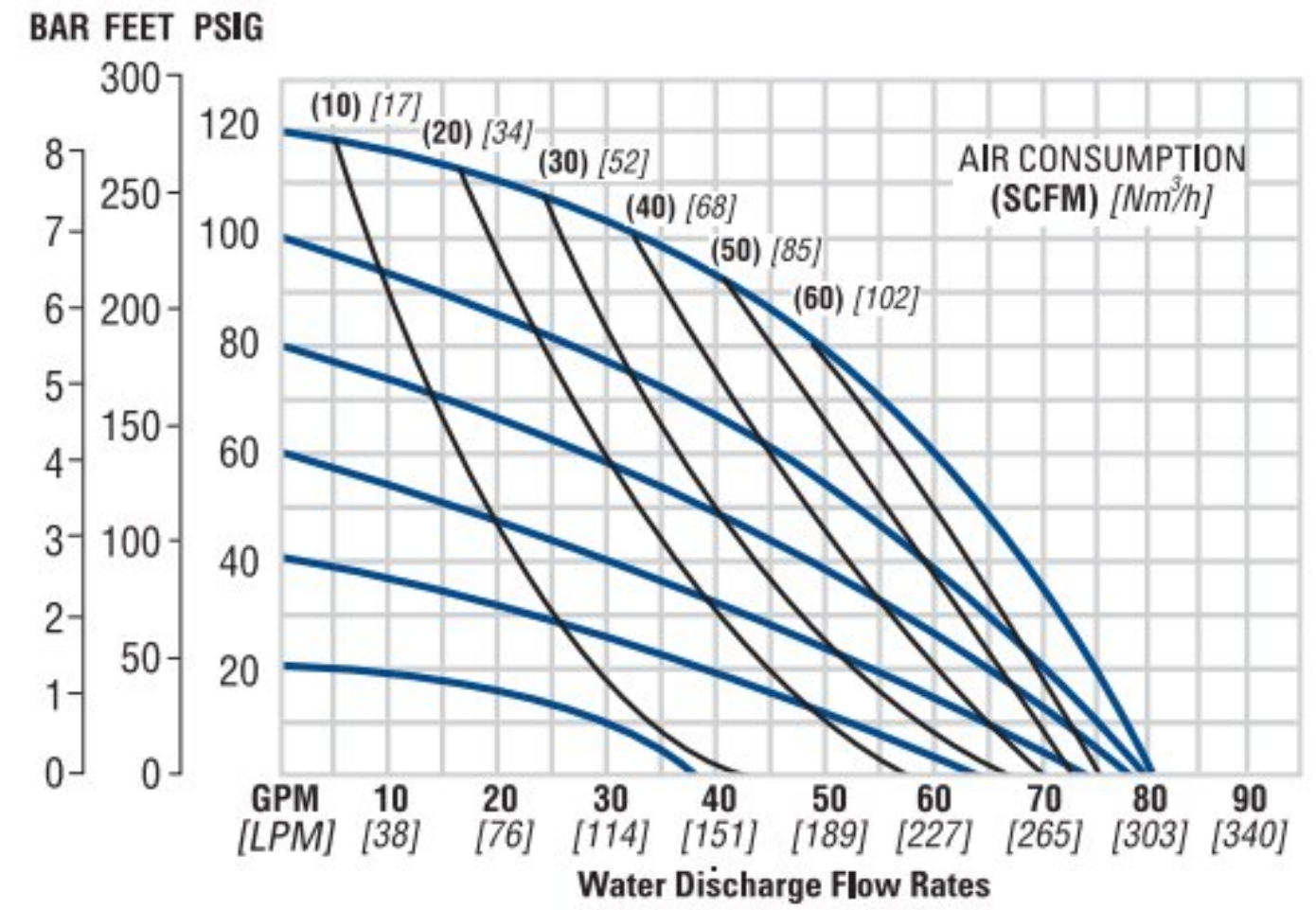

P8

51 mm (2") PRO-FLO CLAMPED METAL PUMP

DESIGNATION: THREADED (P8/A, P8/S, P8/W)



Air Inlet: 1/2" FNPT
 Liquid Inlet: 51 mm (2")
 Liquid Discharge: 51 mm (2")
 Connection Type:
 NPT/BSPT (Threaded)

Max. Flow Rate:
 630 lpm (166 gpm)
 Max. Inlet Pressure:
 8.6 bar (125 psig)
 Max. Size Solids:
 6.4 mm (1/4")

Max. Suction Lift:
 6.9 m Dry (22.7')
 9.3 m Wet (30.6')
 Shipping Weight:
 Aluminum 32 kg (70 lb)
 316 Stainless Steel 51 kg (112 lb)
 Cast Iron 47 kg (104 lb)
 Alloy C 52 kg (114 lb)

Dimensions

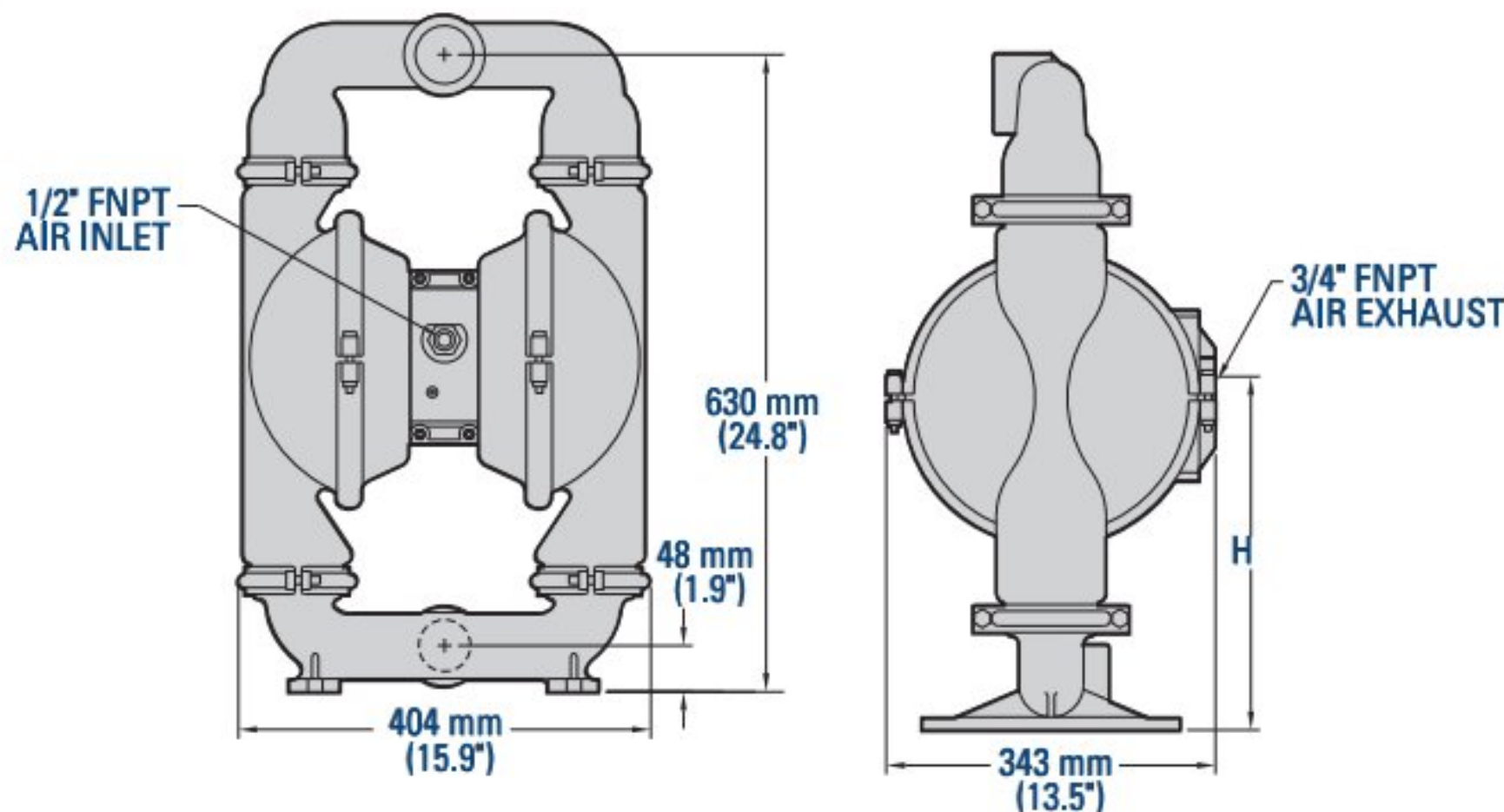

Note that dimensions vary by material. For additional information, please refer to the P8 Metal EOM.

Flow Curve TPE-FITTED

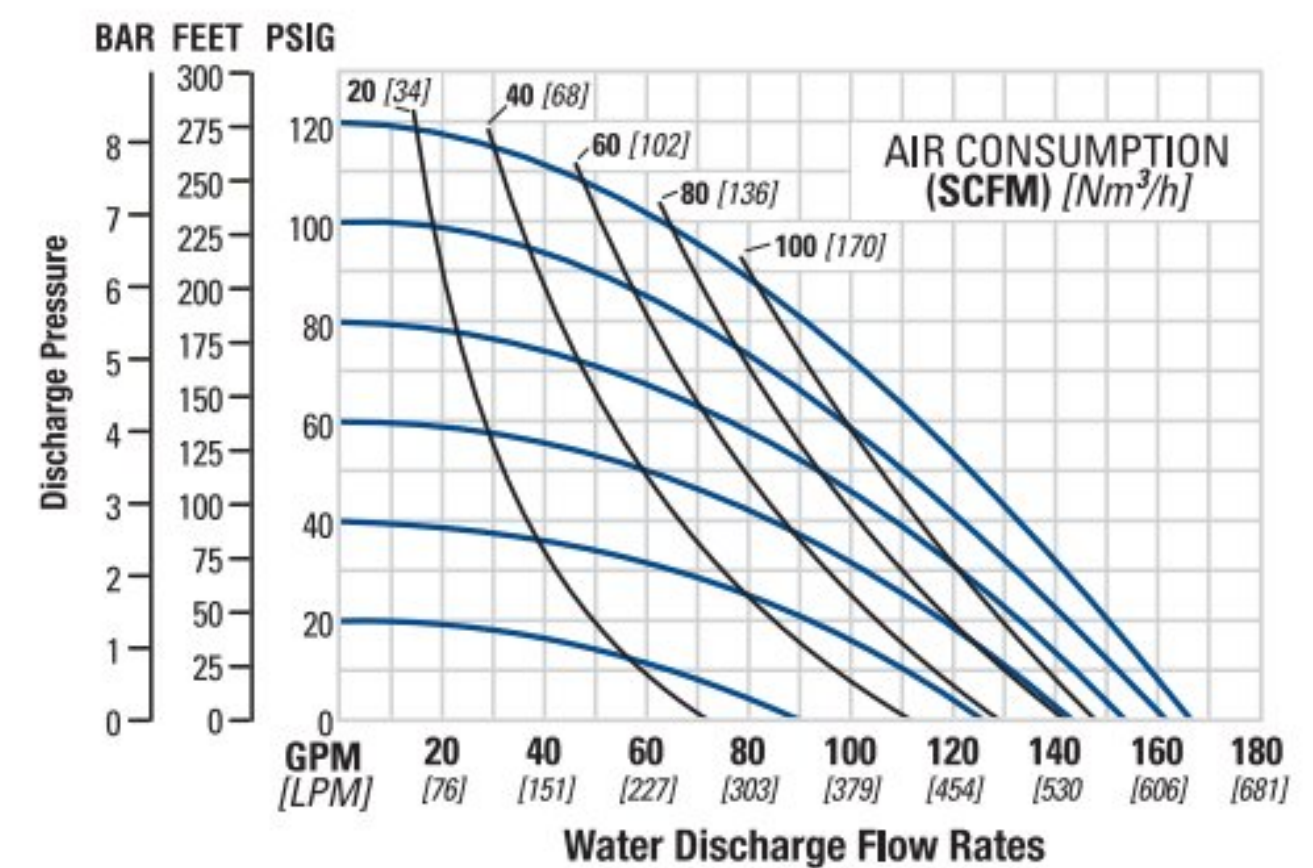



6 mm (1/4") PRO-FLO CLAMPED PLASTIC PUMP

DESIGNATION: THREADED (P.025/K, P.025/P)



Air Inlet: 1/8" FNPT

Liquid Inlet: 6 mm (1/4")

Liquid Discharge: 6 mm (1/4")

Connection Type:

NPT/BSPT (Threaded)

Max. Flow Rate:

18.1 lpm (4.8 gpm)

Max. Inlet Pressure:

8.6 bar (125 psig)

Max. Size Solids:

0.4 mm (1/64")

Max. Suction Lift:

3.05 m Dry (10.0')

9.45 m Wet (31')

Shipping Weight:

1.4 kg (3 lb)

P.025

Dimensions

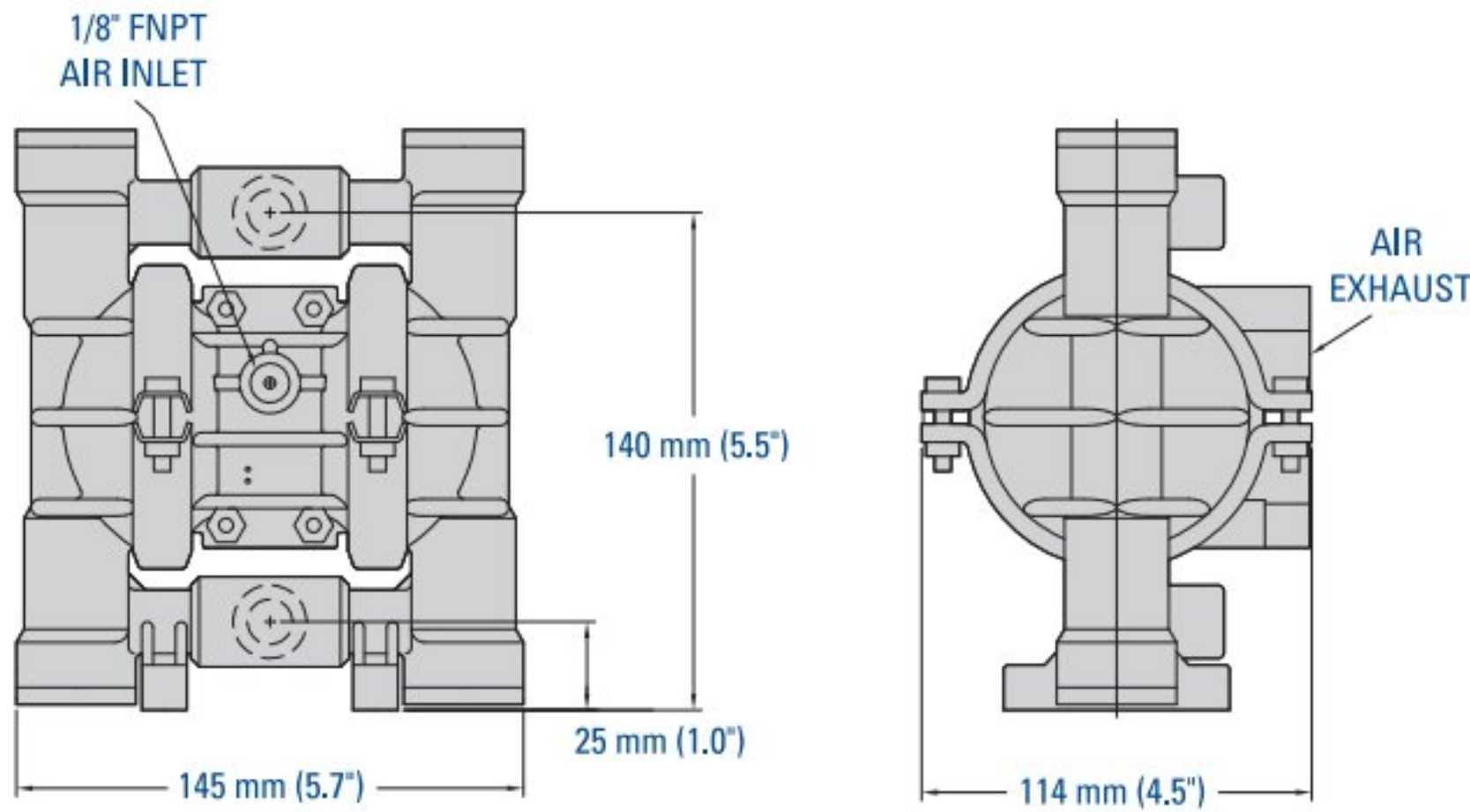

For additional information, please refer to the P.025 Plastic EOM.

Flow Curve TPE-FITTED

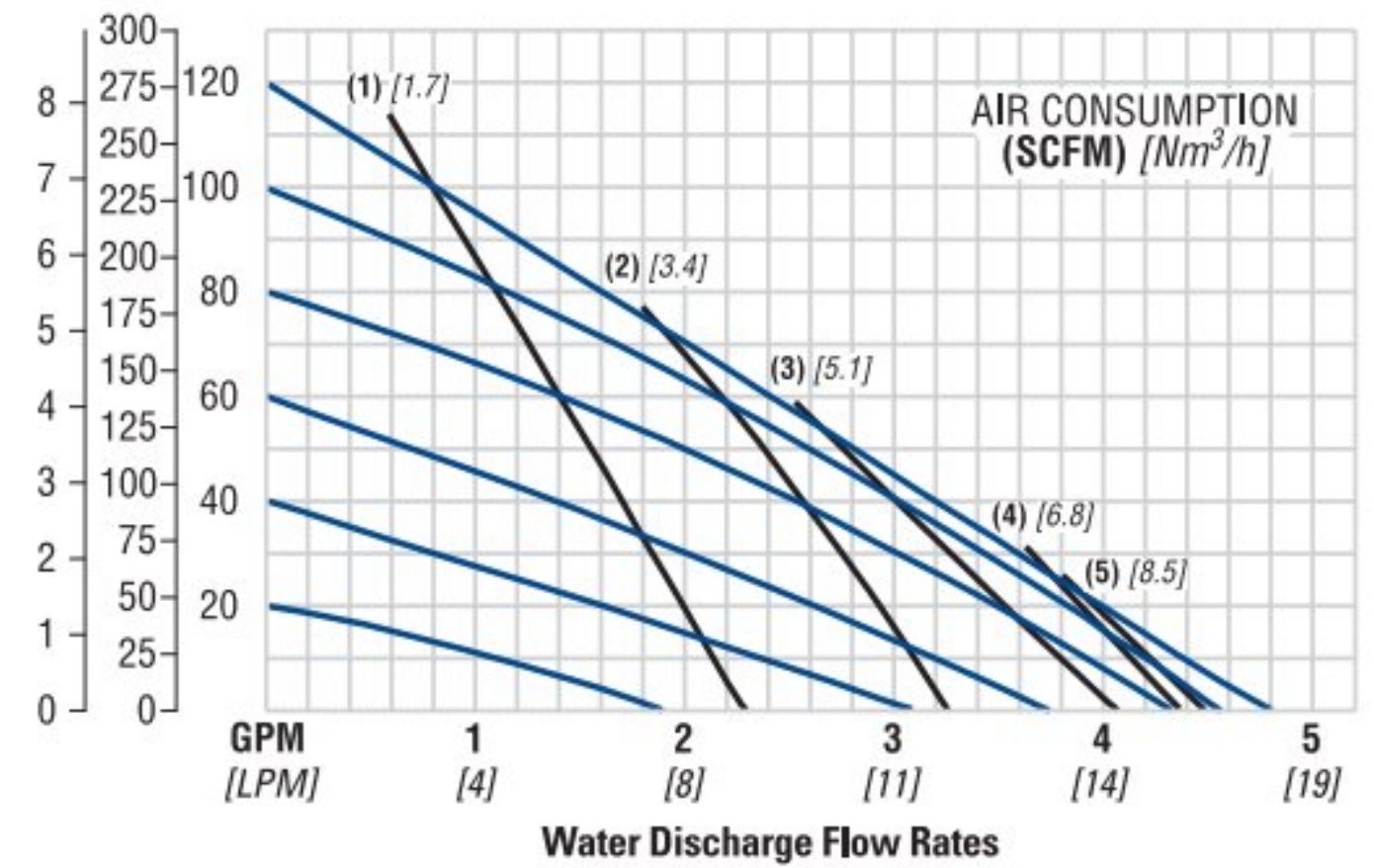

13 mm (1/2") PRO-FLO CLAMPED PLASTIC PUMP

DESIGNATION: THREADED (P1/K, P1/P, P1/T)

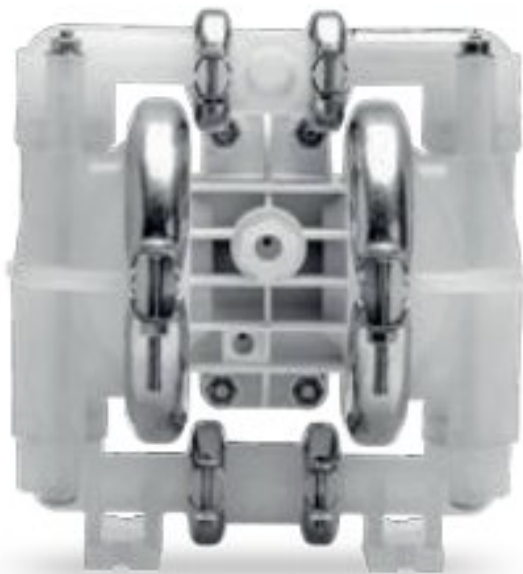

Air Inlet: 1/4" FNPT

Liquid Inlet: 13 mm (1/2")

Liquid Discharge: 13 mm (1/2")

Connection Type:

NPT/BSPT (Threaded)

Max. Flow Rate:

56.8 lpm (15 gpm)

Max. Inlet Pressure:

8.6 bar (125 psig)

Max. Size Solids:

1.6 mm (1/16")

Max. Suction Lift:

6.1 m Dry (20')

9.8 m Wet (32.0')

Shipping Weight:

Polypropylene 4 kg (9 lb)

PVDF 5 kg (11 lb)

P1

Dimensions

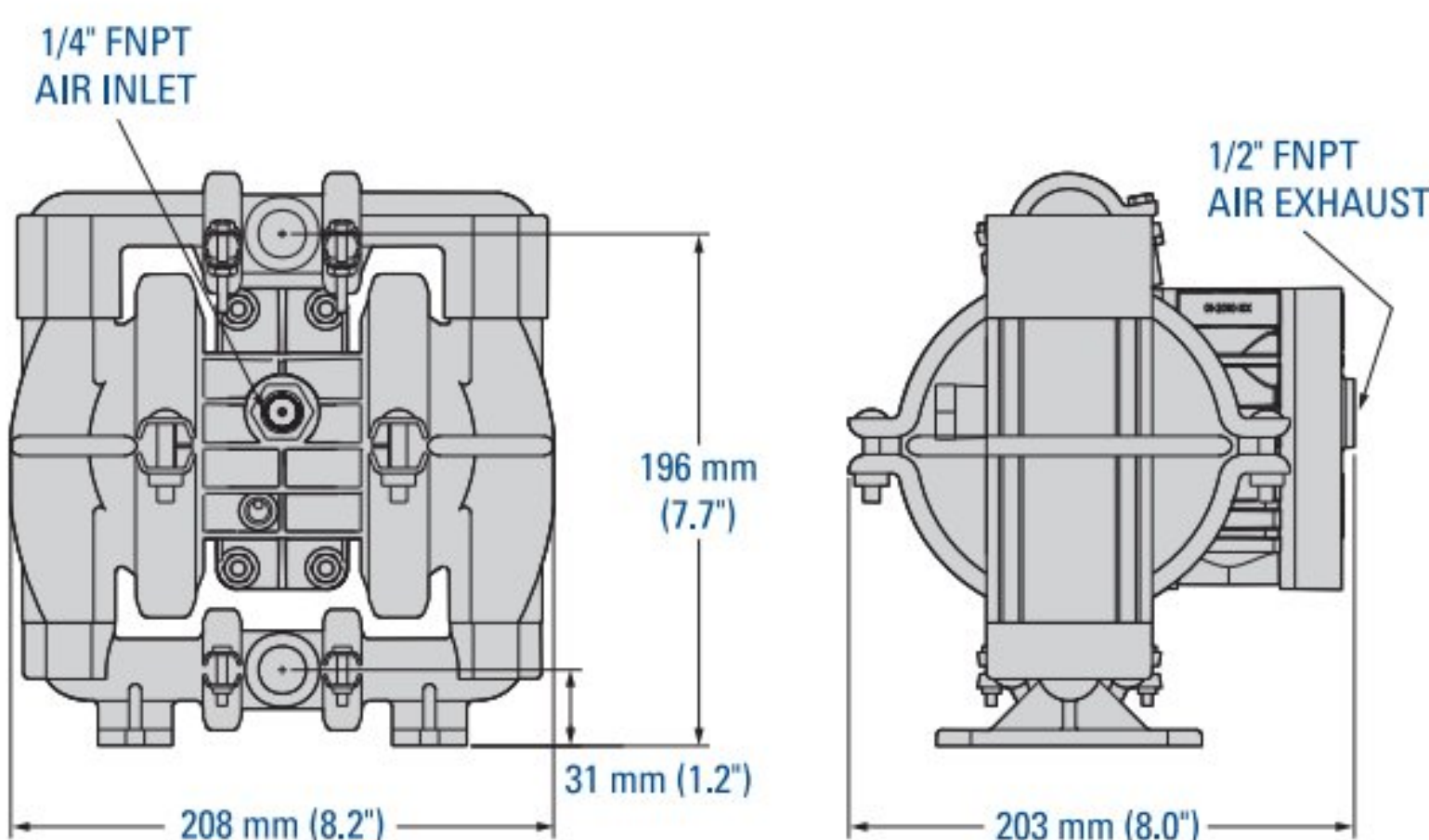

For additional information, please refer to the P1 Plastic EOM.

Flow Curve TPE-FITTED

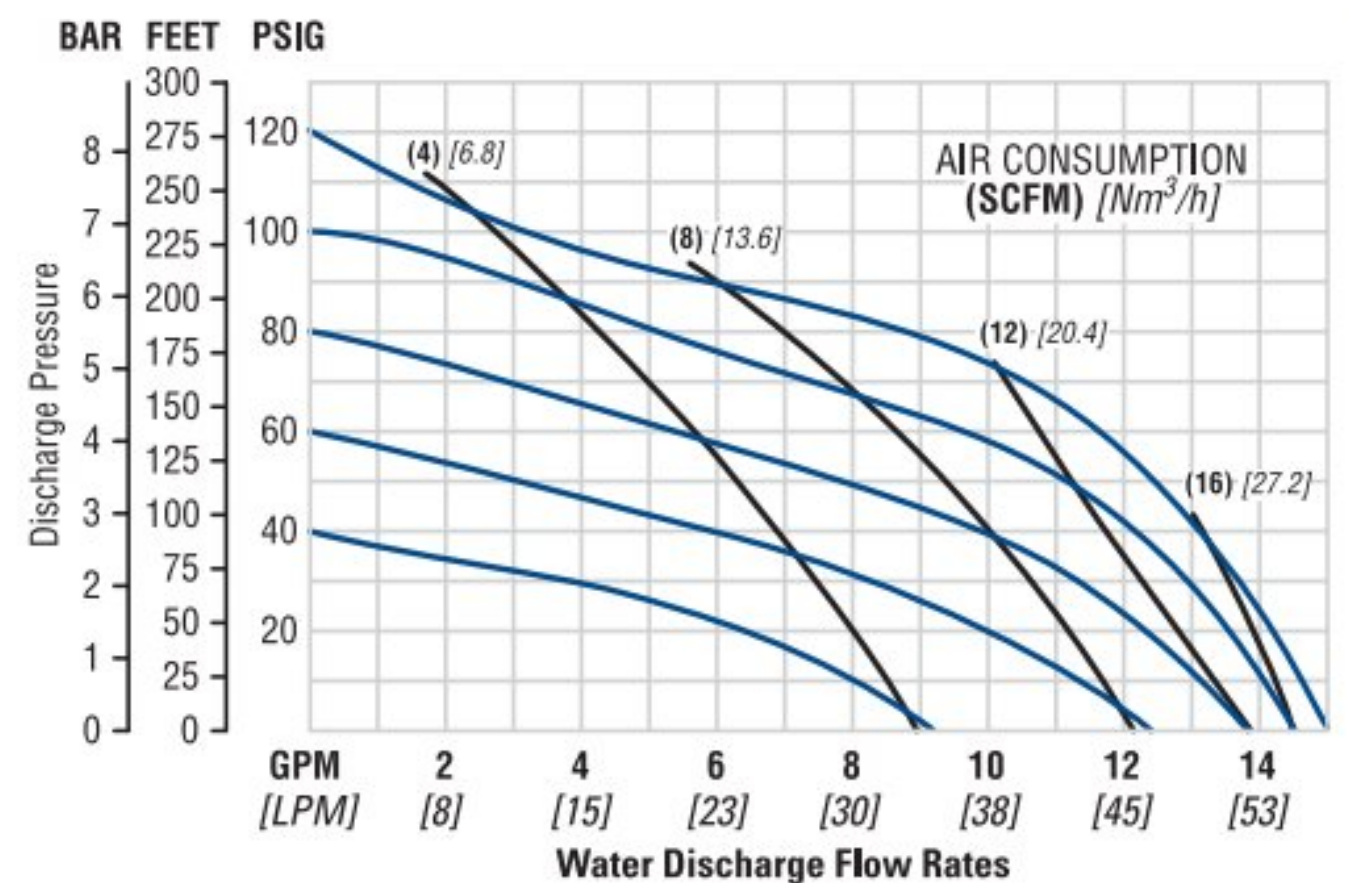

25 mm (1") PRO-FLO CLAMPED PLASTIC PUMP

DESIGNATION: FLANGED (P2/K, P2/P)

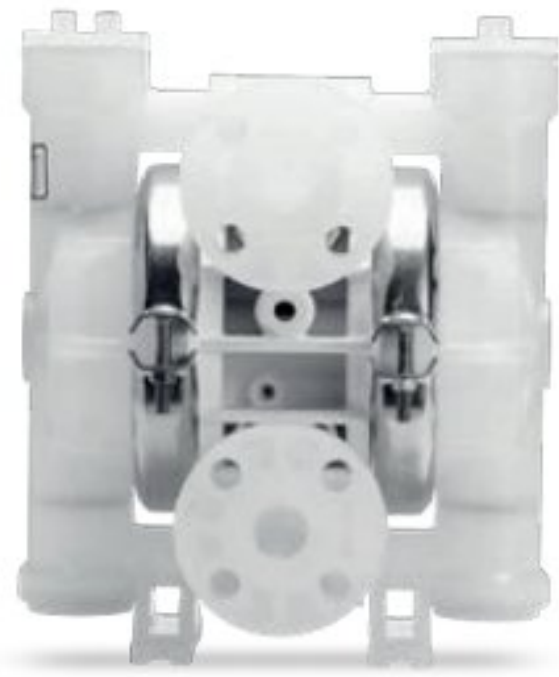

P2

Air Inlet: 1/4" FNPT

Liquid Inlet: 25 mm (1")

Liquid Discharge: 25 mm (1")

Connection Type:

DIN/ANSI (Flanged)

Max. Flow Rate:

140 lpm (37 gpm)

Max. Inlet Pressure:

8.6 bar (125 psig)

Max. Size Solids:

3.2 mm (1/8")

Max. Suction Lift:

5.5 m Dry (18.0')

8.8 m Wet (29.0')

Shipping Weight:

Polypropylene 8 kg (18 lb)

PVDF 10 kg (23 lb)

Dimensions

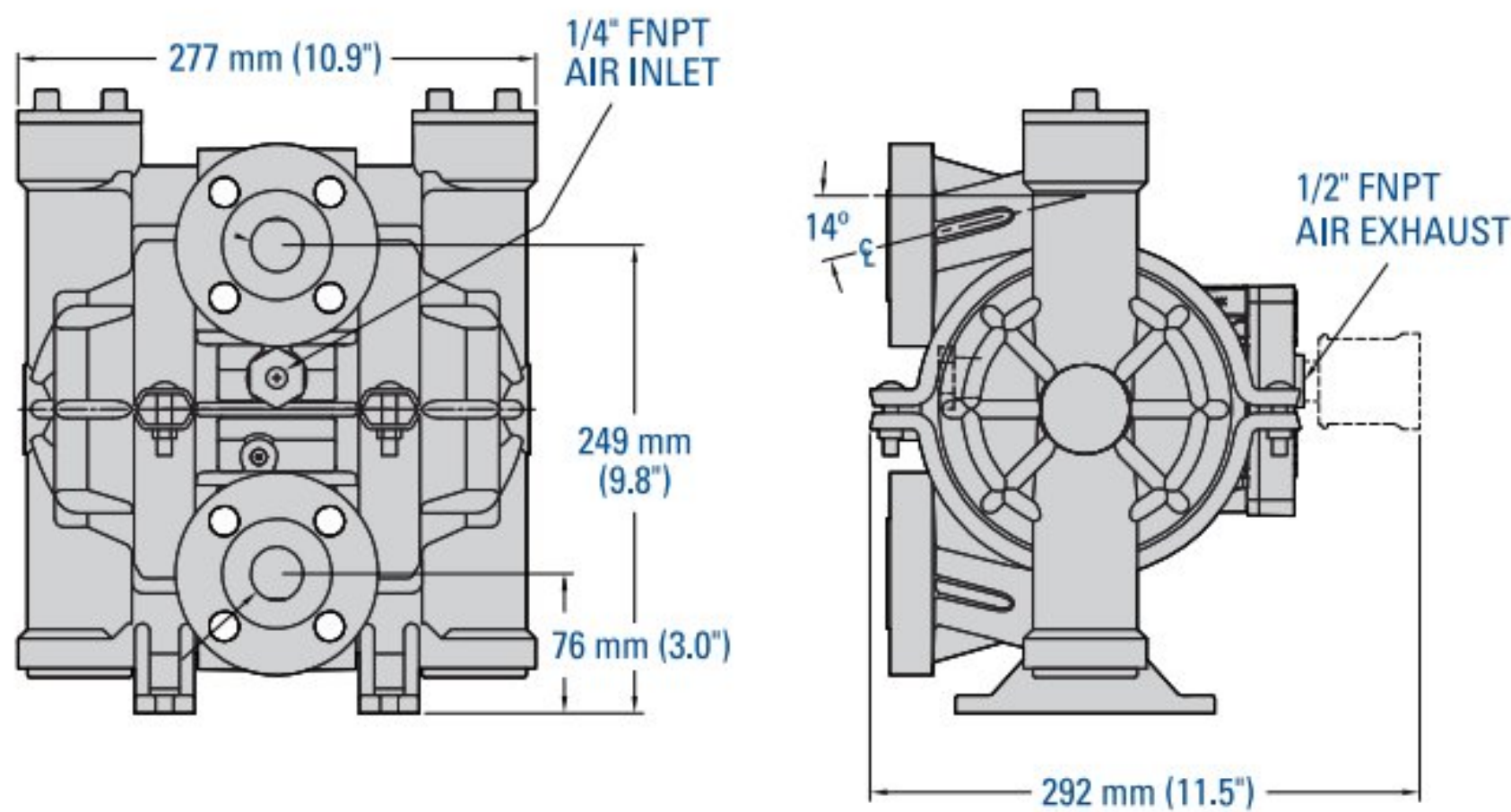

For additional information, please refer to the P2 Plastic EOM.

Flow Curve TPE-FITTED

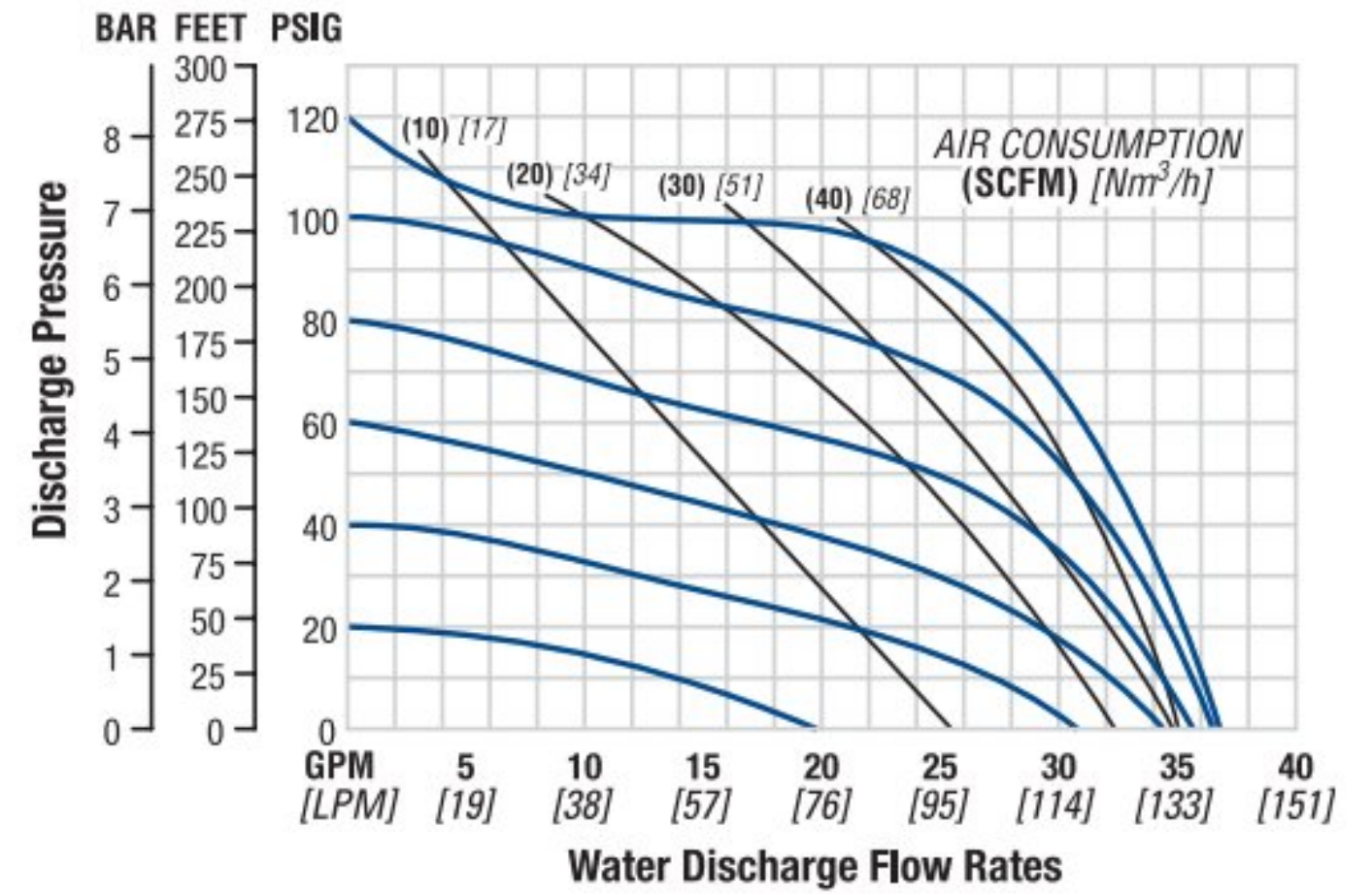

38 mm (1-1/2") PRO-FLO CLAMPED PLASTIC PUMP

DESIGNATION: FLANGED (P4/K, P4/P, P4/T)



P4

Air Inlet: 1/2" FNPT

Liquid Inlet: 38 mm (1-1/2")

Liquid Discharge: 38 mm (1-1/2")

Connection Type:

DIN/ANSI (Flanged)

Max. Flow Rate:

354 lpm (94 gpm)

Max. Inlet Pressure:

8.6 bar (125 psig)

Max. Size Solids:

4.8 mm (3/16")

Max. Suction Lift:

4.88 m Dry (16.0')

9.3 m Wet (30.6')

Shipping Weight:

Polypropylene 16.8 kg (37 lb)

PVDF 21.3 kg (47 lb)

Dimensions

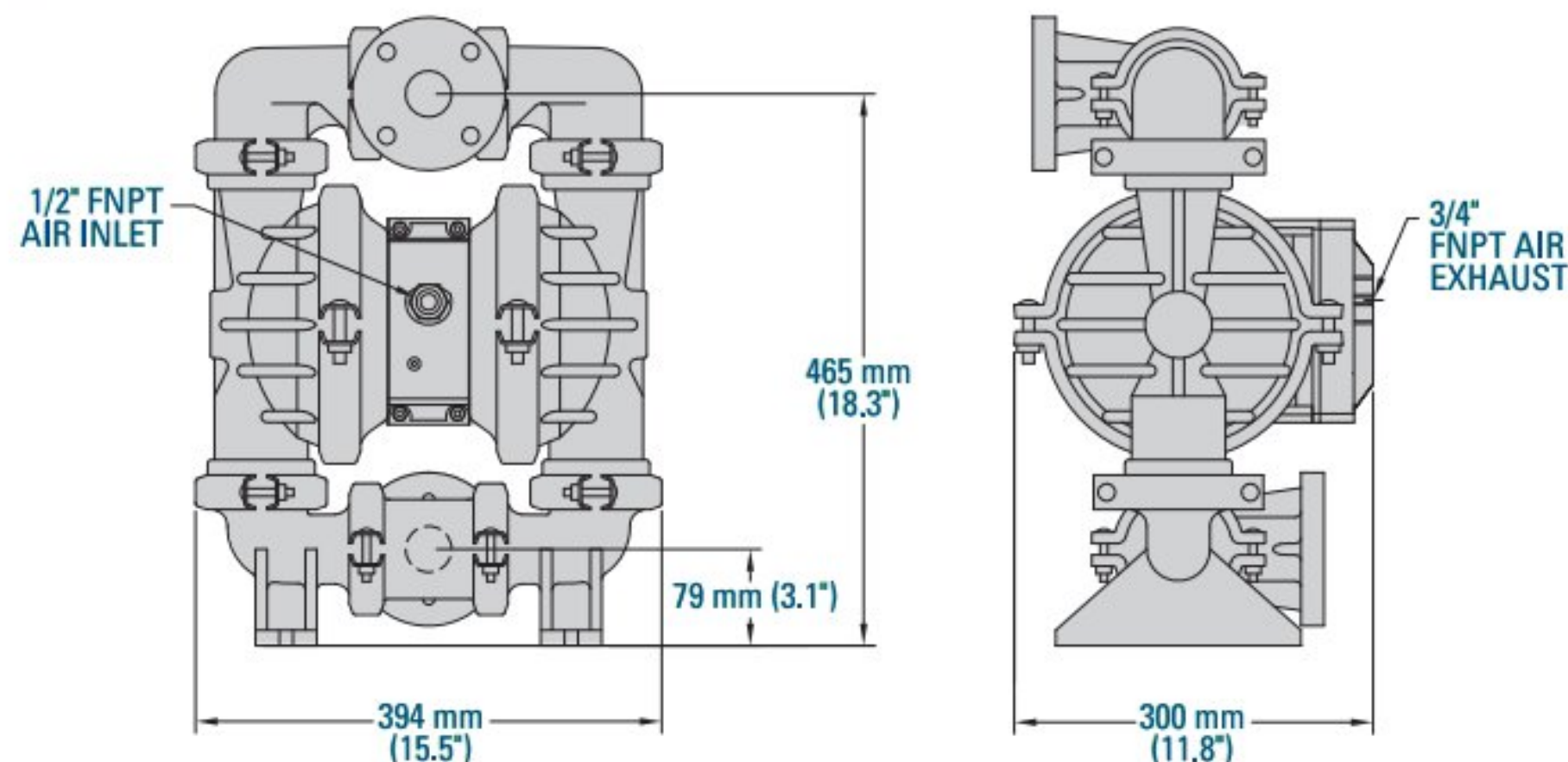

Note that dimensions vary by material. For additional information, please refer to the P4 Plastic EOM.

Flow Curve TPE-FITTED

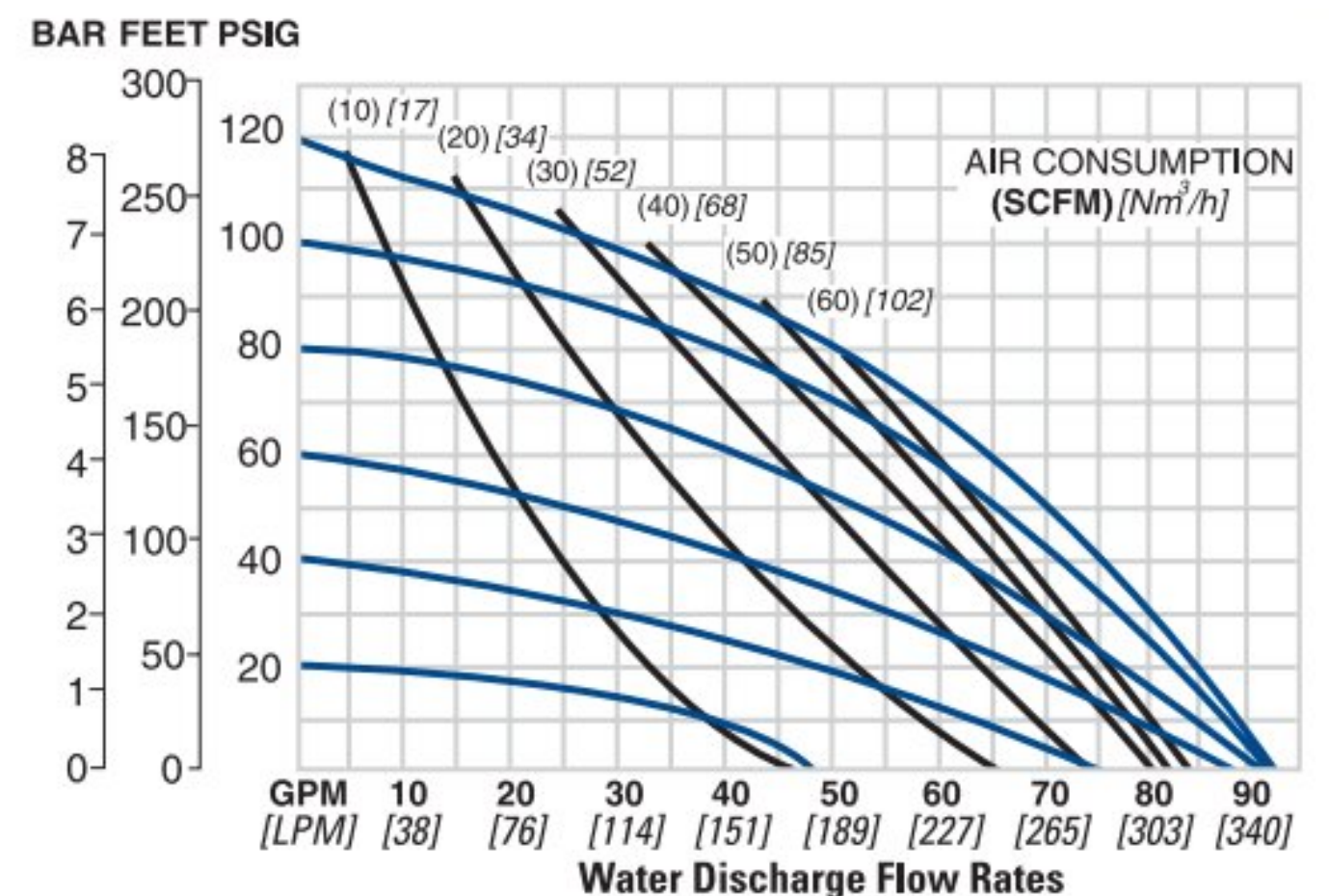

51 mm (2") PRO-FLO CLAMPED PLASTIC PUMP

DESIGNATION: FLANGED (P8/P)



P8

Air Inlet: 1/2" FNPT

Liquid Inlet: 51 mm (2")

Liquid Discharge: 51 mm (2")

Connection Type:

DIN/ANSI (Flanged)

Max. Flow Rate:

591 lpm (156 gpm)

Max. Inlet Pressure:

8.6 bar (125 psig)

Max. Size Solids:

6.4 mm (1/4")

Max. Suction Lift:

7.4 m Dry (24.4')

8.6 m Wet (28.4')

Shipping Weight:

Polypropylene 34 kg (75 lb)

PVDF 43 kg (95 lb)

Dimensions

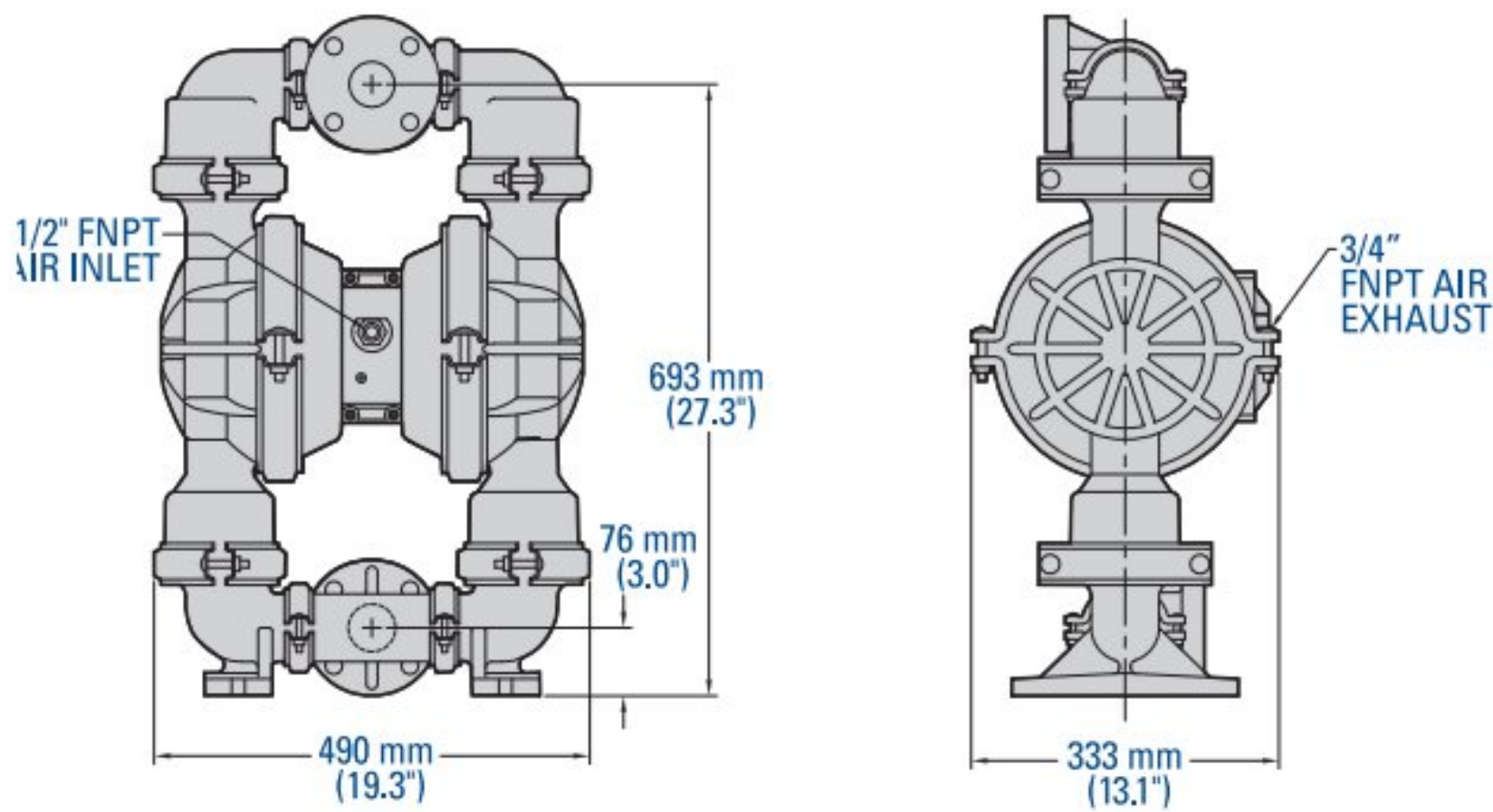

Note that dimensions vary by material. For additional information, please refer to the P8 Plastic EOM.

Flow Curve TPE-FITTED

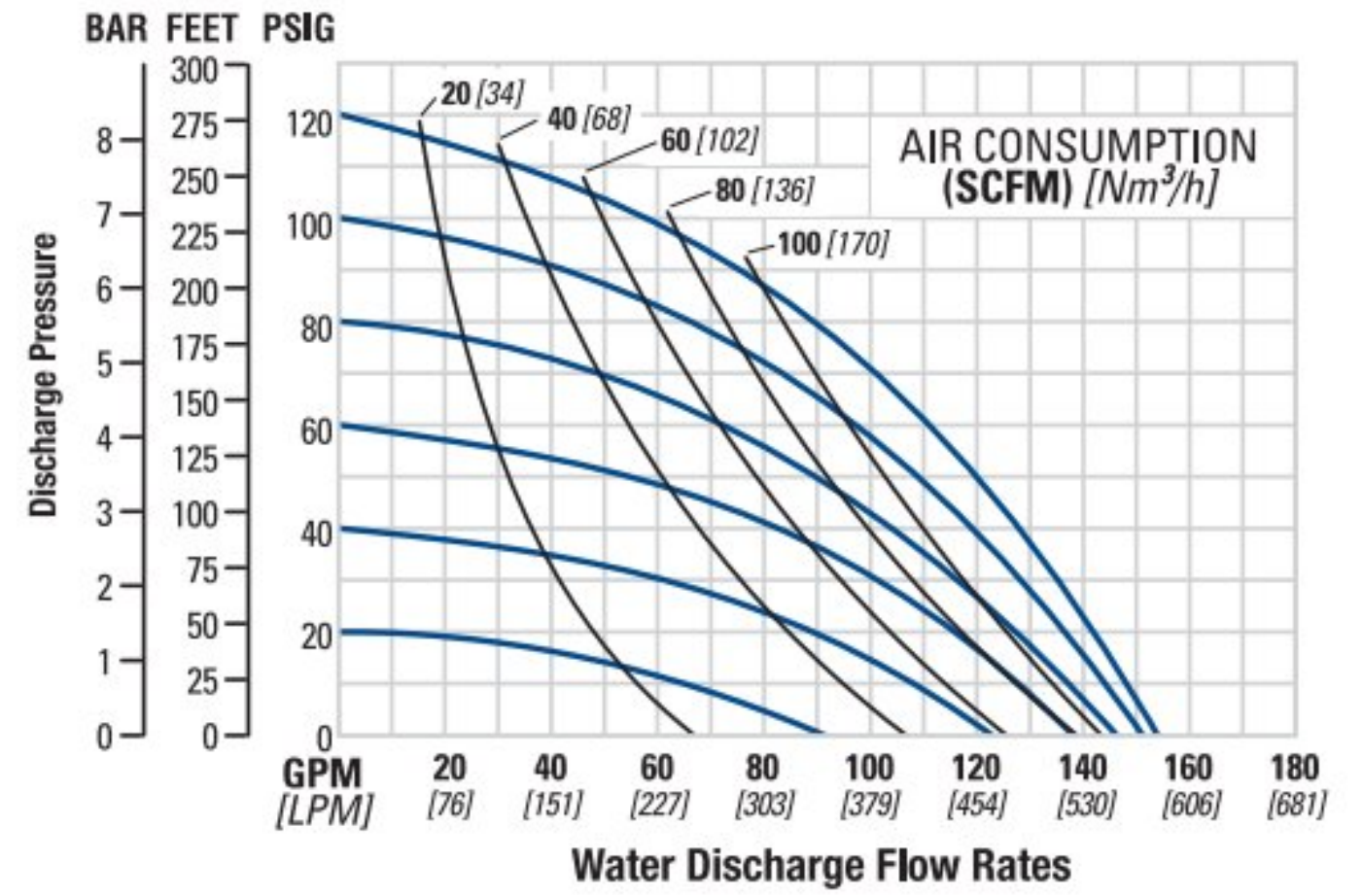

WILDEN®

PSG
22069 Van Buren Street
Grand Terrace
CA, 92313-5651
USA
P: +1 (909) 422-1730
F: +1 (909) 783-3440
wildenpump.com



Where Innovation Flows

WIL-19070-C-05

Authorized PSG® Partner:

Copyright 2019 PSG®, a Dover company

airpumping.co.uk
est. 1979.  **01708 259870**

PSG® reserves the right to modify the information and illustrations contained in this document without prior notice. This is a non-contractual document. 06-2019