

ARGAL

CHEMICAL PUMPS

ASTRA range

***Air operated double
diaphragm pumps***

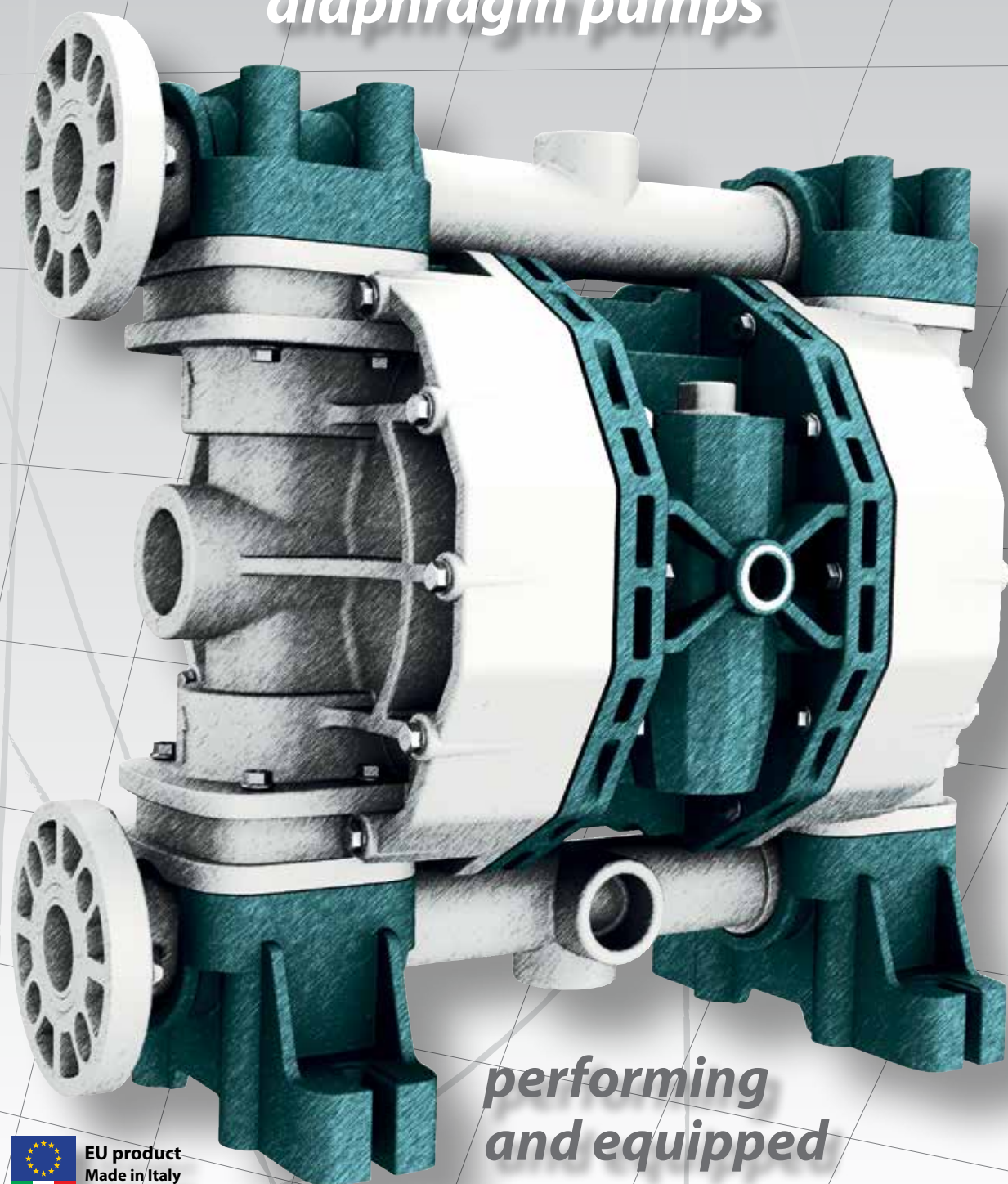

***performing
and equipped***



EU product
Made in Italy

Argal manufactures since 1973 horizontal and vertical centrifugal pumps made of thermoplastic and fluoro polymer chemically resistant materials and its design has been always innovative and appreciated worldwide.

The company complies to the quality system ISO 9001:2000 certified by the Swiss association for quality and Management System SQS belonging to the International Certification IQ Network.

Argal with its new air operated double diaphragm pumps "ASTRA" joins the group of the major European manufacturers of such versatile pumps meant for a broad choice of industries and type of liquids ranging from low to high viscosity, neutral or highly corrosive or even edible (food industry).

PUMPS CONFIGURATION

Pump with reciprocating coaxial chambers with in built valves seats and manifolds located above and below of the chambers (R version, reversible, excluded).

Un balanced air distributor with air spring assisted differential air distributor spool.

Separate pilot spool valve coaxial to the shaft of the diaphragm. (mod. 50C excluded).

Air distributor command reversed at the end of each stroke of the pilot spool valve.

Air flow to diaphragms' pressurisation chambers adjustable. Performance regulation on request from the model 50 and above.

OPERATING PRINCIPLE

Astra pump are double chamber volumetric pumps.

The diaphragms linked by a common shaft move of alternative motion within coaxial chambers and are displaced by pressurised air alternatively delivered to their rear side by an air distributor such that while one diaphragm draws the fluid into one chamber from a common manifold the other diaphragm pumps the fluid from the opposite chamber in to the other common manifold.

SIZES

Depending upon the application we propose different designs for the same pump size aimed to obtain specific benefits like compact dimensions, reduced cost or superior performance.

Currently the range proposed includes the sizes 1/4" - 3/8" - 1/2" - 3/4" - 1" - 1 1/4" - 1 1/2" - 2". In the near future we will manufacture the larger sizes 3" and 4".

MAIN CHARACTERISTICS

- Can run dry.
- Dry lift up to 6 m.
- Operates pneumatically. Doesn't need electrical actuators.
- Stall free pneumatic circuit.
- Easy to install.
- Submersible.
- Lube free.
- Adjustable flow.
- Pumps fluids laden with solids.
- Pumps viscous liquids.
- Pumps liquid with low flash point.

ATEX

All metallic and plastic standard executions are adequate to operate in environments at risk of explosion classified as "Zone 2" (Series II 3/3GD IIB T 135°C) of European ATEX regulation.

For operations in ATEX areas classified as "Zone 1" (II 2/2gd IIB T 135°C) Argal offers pumps manufactures with conductive parts for all thermoplastic and metallic version.

INSTALLATION

ASTRA AODD pumps can be installed like here illustrated for the operations of transfer, feeding, circulation, injection, emptying, dosage.

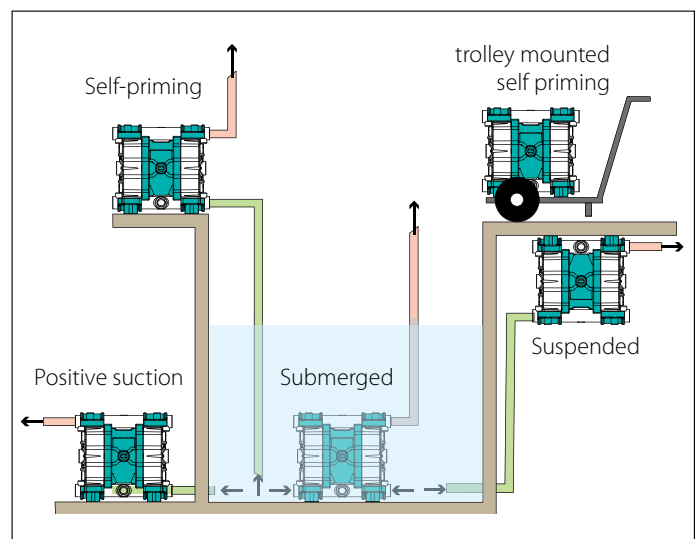

In this catalog:

Introduction.....	page 2-3
DDA 25R – 38R – 50R (1/4" - 3/8" - 1/2")	page 4-5
DDA 38C - 50C (3/8" - 1/2")	page 6-7
Presentation of pumps "Normal" and "Progress".	page 8-9
DDA 50 – 75 – 100C (1/2" - 3/4" - 1")	page 10-11
DDA 100 – 125 (1" - 1 1/4")	page 12-13
DDA 150 – 200 (1 1/2" - 2")	page 14-15
Presentation ASTRAFOOD.....	page 16-17
ASTRAFOOD - DFA 75 – 125	page 18
ASTRAFOOD - DFA 150 – 200.....	page 19
Pulsation dampeners SELENE.....	page 20-21
General technical notes	page 22-23
Main application sectors	page 24

MATERIAL OF CONSTRUCTION

Argals' AODD pumps are manufactured either with thermoplastic or metallic materials.

Available thermoplastic materials are glass fibre reinforced polypropylene (GFR PP), and carbon fibre filled polyvinylidene fluoride (CFF PVDF); construction with pure PVDF is available for a restricted range of models.

PP: resists to aqueous solutions of acids alkalis, salts and several organic solvents; is not resistant to concentrated oxidant acids.

PVDF: resists to acids, saline solutions, aromatics hydrocarbons, aliphatic and chlorinates, alcohols and halogens.

Metallic pumps are made of Aluminium e Stainless Steel SUS 316 for industrial use or of electro polished Stainless Steel SUS 316 with clamp connections and compliant to FDA regulations for food application.

CODES AND APPLICATIONS

table 1

Code	Pump case material	Characteristics Indications Applications
WR	GFR - PP	Good chemical resistance (diluted acids) ; max. temperature 75°C
FC	CFF-PVDF	Excellent chemical resistance (concentrated acids); max. temperature 95°C
DF	PVDF	Excellent chemical resistance;
SS	SUS 316	Strong alkali (hydroxides); high Viscosity high temperature max.150°C
AL	Aluminum	Paint, Solvents, various hydrocarbons; low replacement cost in case of abrasion
SP	SUS 316 polished	Auxiliary services in Food Pharmaceuticals and Cosmetic Industries

CODE AND APPLICATIONS OF WETTED PARTS

table 2

Code	Diaphragm	Balls	Ball seats	Application
HT DZ	PTFE	EPDM	Polyethylene	Abrasion and average chemical resistance
MT Z	Santoprene®	PTFE	Polyethylene	Depuration (economical alternative to execution 13)
HTT Z	PTFE	PTFE	Polyethylene	Standard version; Depuration, filtered oil; low noise level)
HT S Z	PTFE	SUS 316	Polyethylene	Depuration (As execution 13 but with heavy ball)
MS Z	Santoprene®	SUS 316	Polyethylene	Depuration (economical alternative to 13, mild liquids with presence of solid)
MDS	Santoprene®	EPDM	SUS 316	Depuration (economical alternative to 13 in presence of solids)
HTSS	PTFE	SUS 316	SUS 316	Dense fluids; Crude Oil; best dry lift
MSS	Santoprene®	SUS 316	SUS 316	Dense fluids
HTTK	PTFE	PTFE	E-CTFE	Excellent chemical resistance; ultra Pure liquids
HTTS	PTFE	PTFE	SUS 316	Solvents; Inks; paint; enamels
HTTA	PTFE	PTFE	Aluminum	Economical for pure hydrocarbons
HTA	Keyflex®	PTFE	Aluminum	Economical for dirty hydrocarbons
HTTS	PTFE	PTFE	SUS 316 polished	Auxiliary services food and / cosmetic sector
HTSS	PTFE	SS 316	SUS 316 polished	Auxiliary services food sector / cosmetics; high Viscosity

Thermoplastic diaphragms

Offer high chemical resistance, abrasion resistance and long life; are made of Keyflex®, Santoprene® and Polyurethane; the broad range of application these materials are adequate to, eases the choice of the correct pump execution.

Elastomeric diaphragms

Deploy blend of rubbers embedding nylon made reinforcing mesh designed to increase their mechanical resistance. Most common elastomeric rubbers are nitrilic (NBR) and ethylene propylene diene monomer (EPDM) based. On request we deliver also fluorinated rubber FKM diaphragms (e.g.: Viton®).

PTFE diaphragms

Il PTFE is the fluoro-polymer material with the broadest chemical resistance.

Our PTFE diaphragms are manufactured with a special process to be flexible and resistant.

In our ASTRA pumps the PTFE diaphragm is always backed up by a rear diaphragm of thermoplastic rubber which increases the resistance and its service life.



DDA 25 R - 38 R - 50 R (Reversible) 1/4" - 3/8" - 1/2"

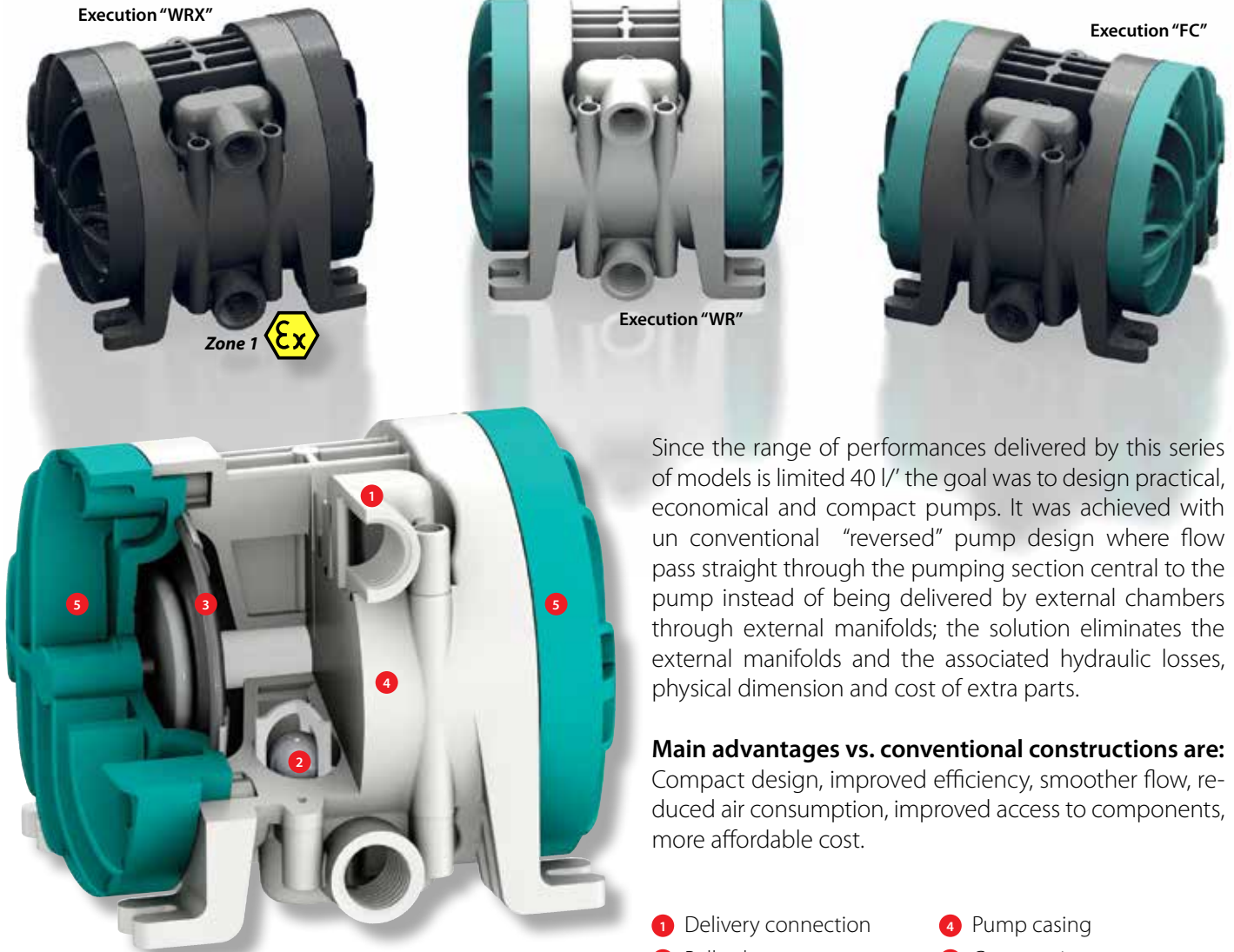

Since the range of performances delivered by this series of models is limited 40 l/ the goal was to design practical, economical and compact pumps. It was achieved with un conventional "reversed" pump design where flow pass straight through the pumping section central to the pump instead of being delivered by external chambers through external manifolds; the solution eliminates the external manifolds and the associated hydraulic losses, physical dimension and cost of extra parts.

Main advantages vs. conventional constructions are: Compact design, improved efficiency, smoother flow, reduced air consumption, improved access to components, more affordable cost.

- 1 Delivery connection
- 2 Ball valve
- 3 Diaphragm
- 4 Pump casing
- 5 Cover casing
- 6 Suction connection

OPERATION SYSTEM

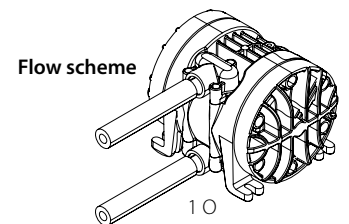
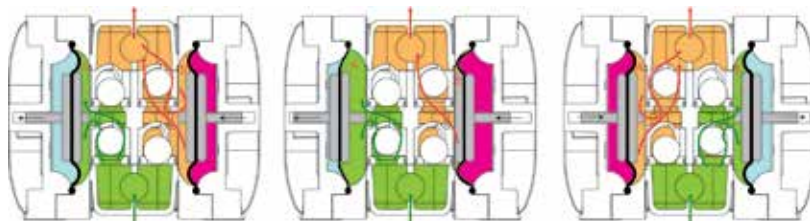

PUMP IDENTIFICATION LABEL

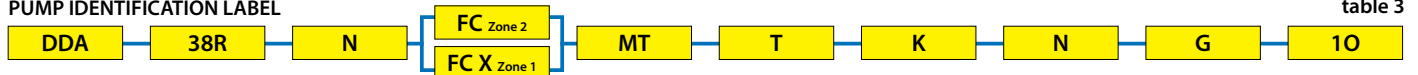

table 3

MODEL				MATERIALS						CONNECTIONS							
COD.	SIZE	COD.	DISTRIBUTOR	COD.	FLUID CHAMBER	ATEX zone 1	COD.	DIAPHRAGMS	COD.	BALLS	COD.	SEATS	COD.	O-Rings	COD.	TYPE	SCHEME
25R	1/4"	N	Standard	WR	GFR-PP	X	H	Keyflex®	T	PTFE	K	PVDF	D	EPDM	G	Thread BSP	10
				FC	CFF-PVDF	X	M	Santoprene®	S	AISI 316	S	AISI 316	V	FPM	N	Thread NPT	
38R	3/8"			DF	PVDF		HT	Keyflex®+PTFE	D	EPDM	A	Aluminum	N	NBR			
		DL	POMC	X	MT	Santoprene®+PTFE	N	NBR	Z	PE UHMW	T	PTFE					
50R	1/2"																

☒ Only ATEX Zone 2 - ☐ Standard connections scheme



DDA 25 R (1/4")

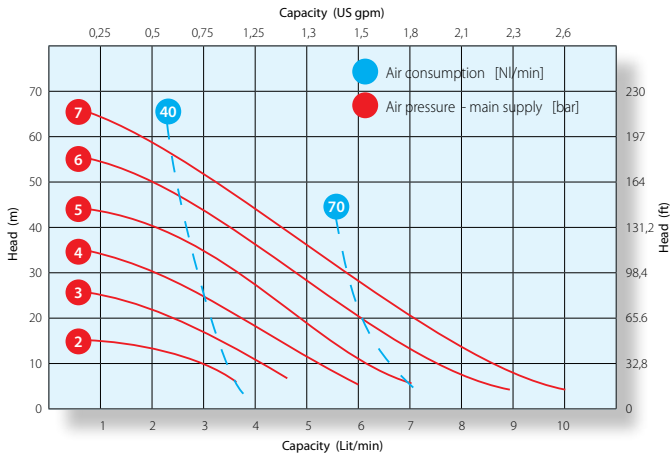

table 4

Technical Data	
Max. capacity	10 l/min
Max. head	70 m
Air inlet	1/4" BSP
Suction Lift	5 m
Max. solids	3 mm
Max. viscosity (positive suction)	8.000 cP
Pump Materials	
WR - Polypropylene + glass fibre (GFR-PP)	
FC - Polyvinylidene fluoride + carbon fibre (CFF-PVDF)	
DF - Polyvinylidene fluoride (PVDF)	
DL - Polyoxymethylene (POMc)	

DDA 38 R (3/8")

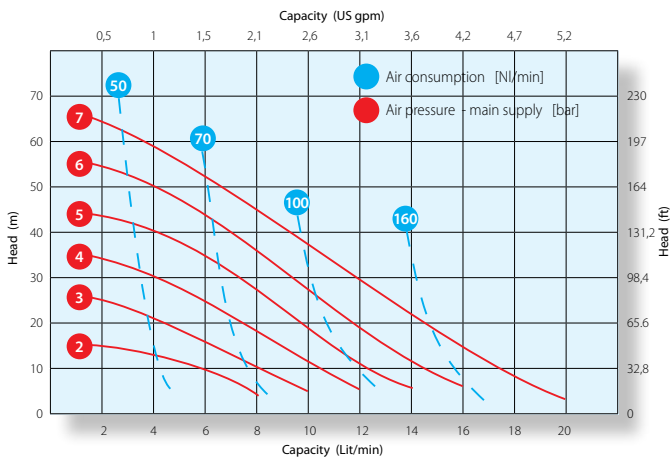

table 5

Technical Data	
Max. capacity	20 l/min
Max. head	70 m
Air inlet	1/4" BSP
Suction lift	5 m
Max. solids	3 mm
Max. viscosity (positive suction)	8.000 cP
Pump Materials	
WR - Polypropylene + glass fibre (GFR-PP)	
FC - Polyvinylidene fluoride + carbon fibre (CFF-PVDF)	
DF - Polyvinylidene fluoride (PVDF)	
DL - Polyoxymethylene (POMc)	

DDA 50 R (1/2")

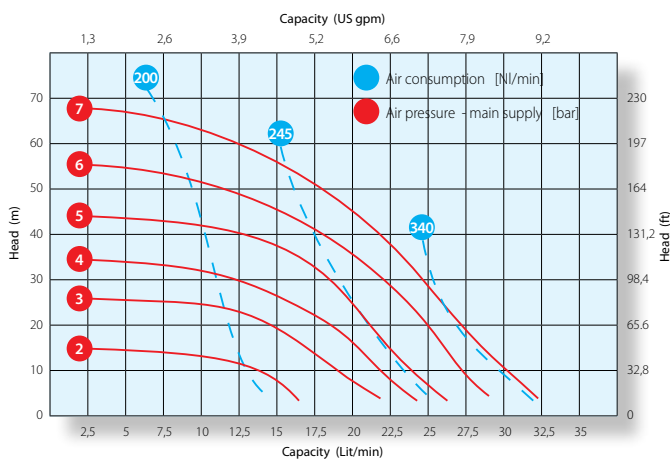

table 6

Technical Data	
Max. capacity	32 l/min
Max. head	70 m
Air inlet	1/4" BSP
Suction lift	5 m
Max. solids	3 mm
Max. viscosity (positive suction)	8.000 cP
Pump Materials	
WR - Polypropylene + glass fibre (GFR-PP)	
FC - Polyvinylidene fluoride + carbon fibre (CFF-PVDF)	
DF - Polyvinylidene fluoride (PVDF)	
DL - Polyoxymethylene (POMc)	

DIMENSIONS

table 7

	Plastic		Metal	
	WR - DL	FC - DF	AL	SS
[mm]	25R 38R 50R	25R 38R 50R		
A	155	155	na	na
B	135	135		
C	125	125		
D	99	99		
E	112	112		
H	93	93		
S	6	6		
T	16,5	16,5		
Peso [kg]	1	1,5		
Connections	Threads			
DnA = DnM	1/4" 3/8" 1/2" 1/4" 3/8" 1/2"			

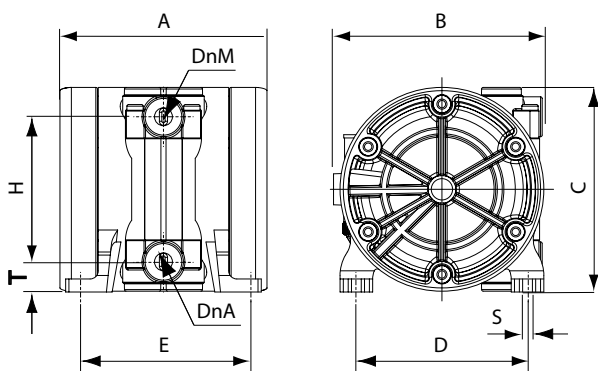

DDA 38 C - 50 C (Compact) 3/8" - 1/2"

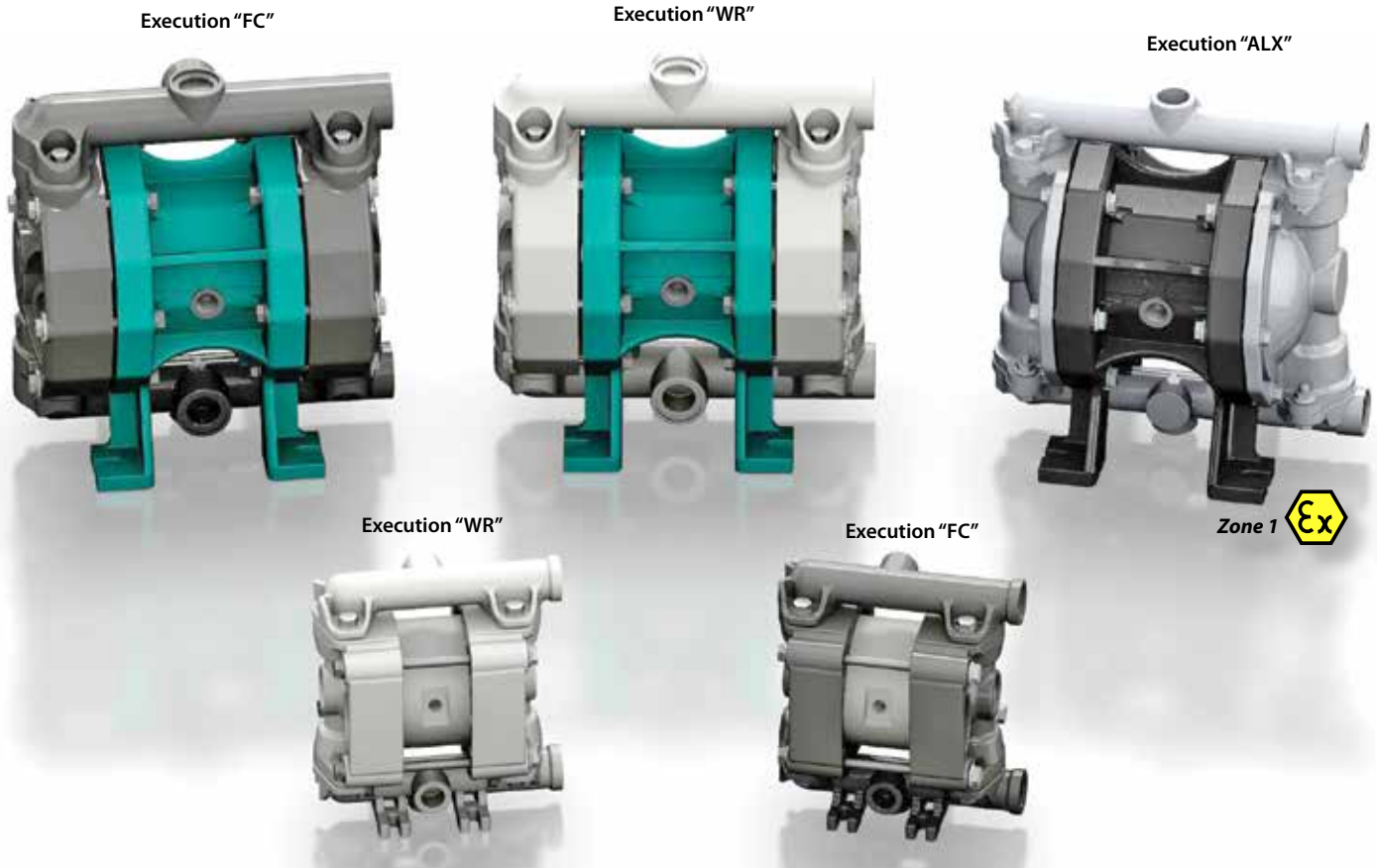

These pumps sizes is in large market demand and Argal wants to offer a perfectly balanced solution with a modern pump complete and characterised by high quality and top performances.

PUMP CONFIGURATION

The pumping casings are bolted to the central casing and to the manifolds by stainless steel bolts to assure reliable operation free from losses of pressurized air or fluids. Valves are integrated in the liquids' chambers to improve

dry lift.

The distributor is unbalanced with air spring assisted differential air distributor spool and command spool integrated in the distributor spool.

The original design of the distributor optimizes the performances of the pumps and contributes to the reduction of air consumption. The pump operates also with minimal pneumatic pressure supply. Flow and speed vary adjusting the air flow while the head depends from the pressure of the air supply.

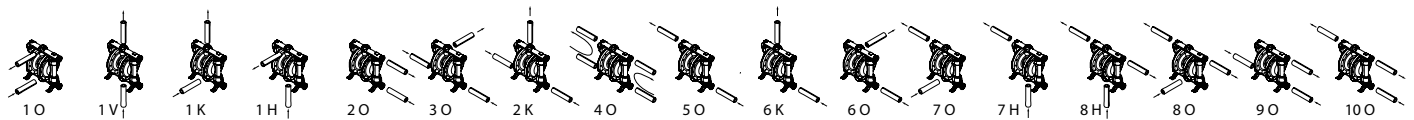

PUMP IDENTIFICATION LABEL

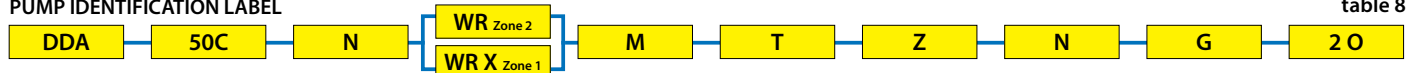
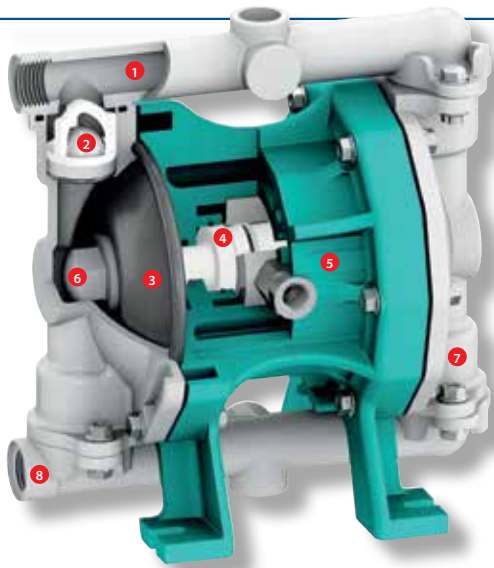

table 8

MODEL		MATERIALS							CONNECTIONS										
COD.	attacchi	COD.	DISTRIBUTOR	COD.	FLUID CHAMBER	ATEX zone 1	COD.	DIAPHRAGMS	COD.	BALLS	COD.	SEATS	COD.	O-Rings	COD.	TYPE	SCHEME		
																	COD.		
38C	3/8"	N	Standard	WR	GFR-PP	X	H	Keyflex®	T	PTFE	K	PVDF	D	EPDM	G	Thread BSP	1O	1V	7H
				FC	CFF-PVDF	X	M	Santoprene®	S	AISI 316 SS	S	AISI 316	V	FKM	N	Thread NPT	1K	1H	8H
				DF	PVDF		D	EPDM	D	EPDM	A	Aluminum	N	NBR	I	Flange (i)	2O	3O	8O
50C	1/2"	N	Standard	AL	Aluminum	X	N	NBR	N	NBR	Z	PE UHMW	T	PTFE			3K	4O	9O
				SS	AISI 316	X	HT	Keyflex®+PTFE			P	PP					5O	6K	10O
							MT	Santoprene®+PTFE									6O	7O	

☐ Only ATEX Zone 2 - (1) Available on request - ☐ Standard connections scheme



- 1 Delivery manifold
- 2 Ball valve
- 3 Diaphragm
- 4 Air pneumatic distributor
- 5 Central casing
- 6 Wetted washer
- 7 Pump casing
- 8 Suction manifold

Major applications:

Ink for flexographic and traditional printing.
 Painting application and appliances.
 Industrial washing and de greasing.
 Fluid transfer from drums.
 Transfer of restricted quantities of fluids.

DDA 38 C (3/8")

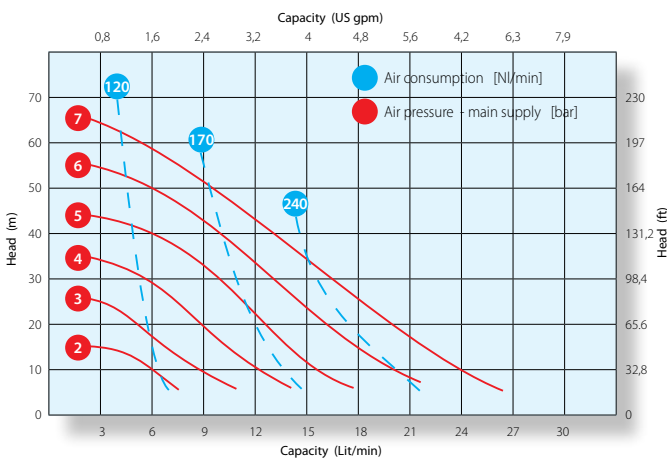

table 9

Technical Data	
Max. capacity	25 l/min
Max. head	70 m
Air inlet	1/8" BSP
Suction lift	5 m
Max. solids	3 mm
Max. viscosity (positive suction)	8.000 cP
Pump Materials	
WR - Polypropylene + glass fibre (GFR-PP)	
FC - Polyvinylidene fluoride + carbon fibre (CFF-PVDF)	
DF - Polyvinylidene fluoride (PVDF)	

DDA 50 C (1/2")

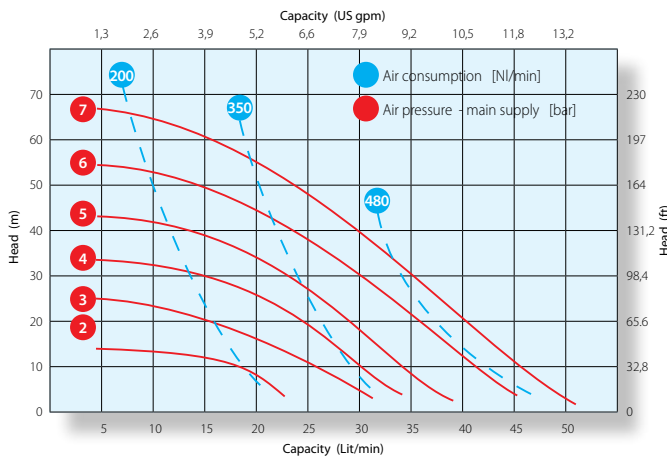
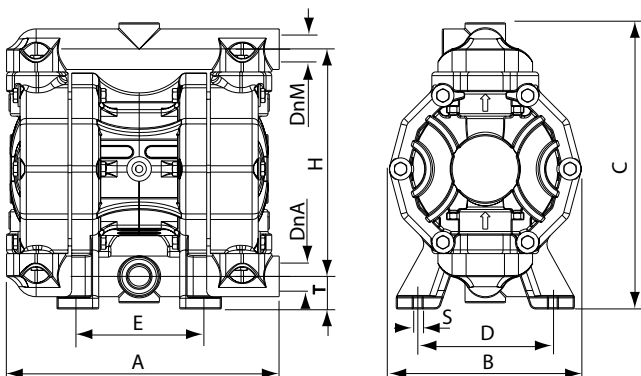

table 10

Technical Data	
Max. capacity	50 l/min
Max. head	70 m
Air Inlet	1/4" BSP
Suction Lift	5 m
Solids pass	3 mm
Max. viscosity (positive suction)	10.000 cP
Pump Materials	
WR - Polypropylene + glass fibre (GFR-PP)	
FC - Polyvinylidene fluoride + carbon fibre (CFF-PVDF)	
DF - Polyvinylidene fluoride (PVDF)	
AL - Aluminum	
SS - SUS 316	



DIMENSIONS

table 11

	Plastic				Metal	
	WR	50C	38C	50C	AL	SS
[mm]	38C	50C	38C	50C	50C	50C
A	146	222	146	222	225	225
B	93	156	93	156	156	156
C	164	233	164	233	230	230
D	47	110	47	110	110	110
E	47	110	47	110	110	110
H	130	185	130	185	183	183
S	6	7	6	7	7	7
T	20	26,5	20	26,5	25,5	25,5
Weight [kg]	2	4	2,5	4,5	5	6
Connections	Threads (°)					
DnA = DnM	3/8"	1/2"	3/8"	1/2"	1/2"	1/2"

(°) ISO-ANSI flanged connections available on request

DDA 50 - 75 - 100 C - 100 - 125 - 150 - 200

The range of pumps with sizes from ½" to 2" offers increased flow compared to common pumps of the same size. This translates in economical advantage for a smaller and less expensive pump can be applied to deliver same performances or in a technical advantage for by same size same performances are delivered at a lesser speed and consequent reduced mechanical stress and wear of all parts. For mentioned reasons the user enjoys a longer operational life, lesser LCC (Life Cycle Cost) and devices with less vibration and attenuated noise compared to conventional pumps.

PNEUMATIC DISTRIBUTOR SYSTEM ARGAL

is made up by:

- Unbalanced air distributor system with pneumatic air assistance.
- Pilot spool coaxial to the rod connecting the diaphragms.
- In built by directional air flow regulator to diaphragms' air chambers.
- Pneumatic signal's management system.

DESCRIPTION OF THE SYSTEM

The unbalanced air distributor, combined with the command valve realises a system with intrinsic stall free characteristics.

In details the pilot spool supplies or cuts off the pressurised air command to the distributor only at the end of each of its strokes.

This arrangement prevents the pilot spool to generate ambiguous commands even at very low pumping speed or low air supply pressures or even with a shut off delivery valve, which typically happens to less sophisticate distributors which in such conditions easily stall.

PUMP CONFIGURATION

ARGAL AODD pumps are available in two version **N**ormal and **P**rogress. Both version are designed an pre set for following options:

- "Two in one" delivery manifold;
- Detection of cycles with normalised probe;
- Extra low pressure operation with actuation circuit of diaphragms independent from pilot command circuit;
- Pneumatic signals in response of the end of run positions of the diaphragms;
- Adaptors to feed air chambers from external source.
- Submersible configuration.

Short description.

It is possible to feed the actuation circuit and the pilot circuit of the distributor with air at different pressures; this allows to deliver the fluid at very low pressures variable at will and always controllable from the outside of the pump without the risk to stall the distributor because of insufficient air command pressure. The actuation circuit (that distributes pressurised air in the chamber of the diaphragms)

fed with air at low pressure, offers performances ideal to fine dose fluids and supply devices operating at low fluid pressure (as spraying guns).

Other connections provide pneumatic signals in correspondence of the extreme positions of the diaphragms. These connections fitted with simple adaptors ease the installation of pneumatic or electric cycle counting devices also adequate to ATEX classified areas if provided with adequate electrical transducers. All pumps are pre set to these functions by connections located in a dedicate space close by to the air distributors' exhaust cover.

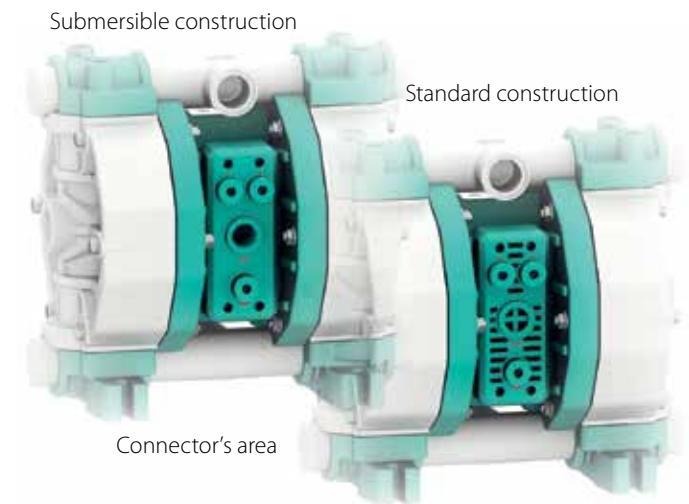

PROGRESS VERSION

All the pump models can be fitted with an integrated control dial distribution valve easily adjustable to set the device on pre set positions optimised to pump problematic fluids as liquids laden with solids or very viscous.

This in built regulator device is valuable for, either at the installation or at later times allows, by selecting the best set up, to fine tune the pump to the specific application thus reducing significantly the air consumption of the pump and its overall efficiency and flexibility.

PADS: THE NEW AIR DISTRIBUTOR AND REGULATOR

To enrich this new series of Argal pumps with new features we introduced in its pneumatic distributor a bidirectional valve; this valve controls the airflow during the pressurisation and de pressurisation of the chamber behind the diaphragms.

Conventional AODD pumps deploy only one air valve applied along the air supply line of the pump (or built in the pump) to control the pressurisation of the air chambers while the release of the pressurised air once stroke is concluded is not controlled and the discharge is rather violent and transmits to the liquid pumped pulsations.

The by directional valve integrated in the central casing of Argal pumps effectively controls both pressurisation and de pressurisation of the air chambers: the flow of the liquid delivered is still impulsive but amplitude of pulsations are significantly smaller and pump operations are easier to be

adapted to the characteristic of the liquid pumped. This original design feature never marketed before is surely a plus that coupled with the high specific efficiency (litre of compressed air per litre of liquid pumped) and low energetic consumption of these pumps makes this a state of the art solution and a new reference point.



Normal Version



Progress Version

- 1 Delivery manifold
- 2 Ball valve
- 3 Diaphragm
- 4 Air Regulator
- 5 Regulation knob
- 6 Command spool
- 7 Central casing
- 8 Wetted washer
- 9 Pump casing
- 10 Suction manifold

OPTIONALS

Batch dosing system.

Pneumatic cycle counter contained in a waterproof box actuates an air operated double diaphragm pump for a pre settable number of cycles; simple, economical and effective device that coupled to an air operated double diaphragm delivers a full pneumatic batch dosing system.

Electronic batch dosing system.

Electronic cycle counter instead of pneumatic compliant to ATEX regulation. Cycle counter with on/off switch output. Compact transducer to be installed at the foreseen pumps' connector delivers to cycle counter on /off signal.

Electric cycle counter.

Compact transducer installable on a foreseen connection of the pump delivers on/off switch signal at any pumping cycle; this signal can be utilized as input for a remote cycle counter device that coupled to the air operated double diaphragm pump may constitute a simple and effective dosing system.

Electric cycle counter.

Electric cycle counter for classified areas. Delivers the same functions of the on/off cycle counter dosing system above described but the transducer is an ATEX classified electronic probe to be installed on the pump by a dedicated adaptor.

Pulsation dampener (see page 22, 23).



ACCESSORIES

- Air regulator kit.
- Pneumatic and electric control valves.
- Connector flange kit.
- Shock adsorber kit for pumps.
- Flexible connections kit.
- Valve adaptors made of pp, pvdf, inox.
- Stainless steel trolley for pumps.

DDA 50 - 75 - 100 C 1/2" - 3/4" 1"



PUMP IDENTIFICATION LABEL

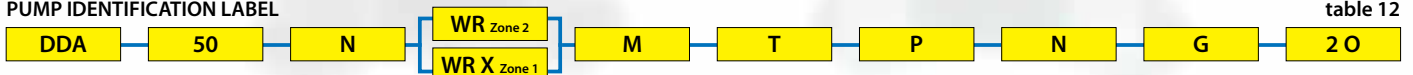

table 12

MODEL				MATERIALS						CONNECTIONS									
COD.	SIZE	COD.	DISTRIBUTOR	COD.	FLUID CHAMBER	ATEX zone 1	COD.	DIAPHRAGMS	COD.	BALLS	COD.	SEATS	COD.	O-Rings	COD.	TYPE	SCHEME		
																	COD.		
50	1/2"	N	Standard	WR	GFR-PP	X	H	Keyflex®	T	PTFE	K	PVDF	D	EPDM	G	Thread BSP	1O	1V	7H
				FC	CFF-PVDF	X	M	Santoprene®	S	AISI 316 SS	S	AISI 316	S	AISI 316	V	FKM	N	Thread NPT	1K
75	3/4"	P	Progress	DF	PVDF		D	EPDM	D	EPDM	A	Aluminum	N	NBR	I	Flange (i)	2O	3O	8O
				AL	Aluminum	X	N	NBR	N	NBR	Z	PE UHMW	T	PTFE				3K	4O
100 C	1"			SS	AISI 316	X	HT	Keyflex®+PTFE									5O	6K	10O
							MT	Santoprene®+PTFE											6O

☐ Only ATEX Zone 2 - (1) Available on request - ☐ Standard connections scheme



DDA 50 (1/2")

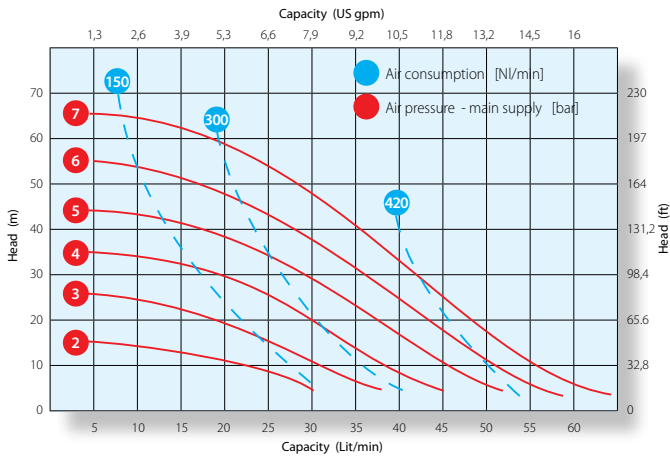

table 13

Technical Data	
Max. capacity	65 l/min
Max. head	70 m
Air Inlet	3/8" BSP
Suction Lift	6 m
Max. Solids	3,5 mm
Max. viscosity (positive suction)	10.000 cP
Pump Materials	
WR - Polypropylene + glass fibre (GFR-PP)	
FC - Polyvinylidene fluoride + carbon fibre (CFF-PVDF)	
DF - Polyvinylidene fluoride (PVDF)	
AL - Aluminum	
SS - SUS 316	

DDA 75 (3/4") DDA 100C (1")

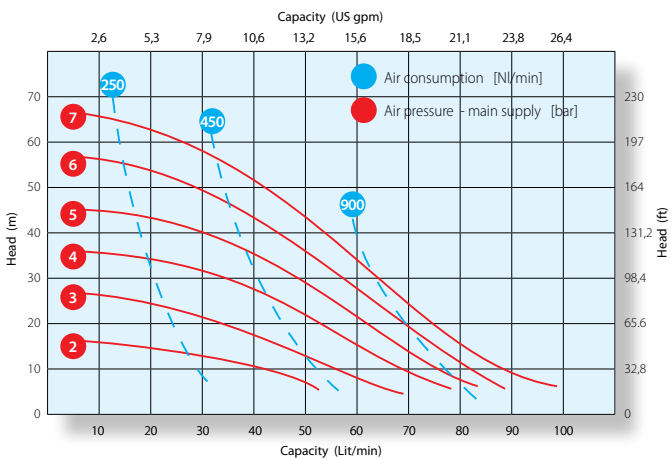
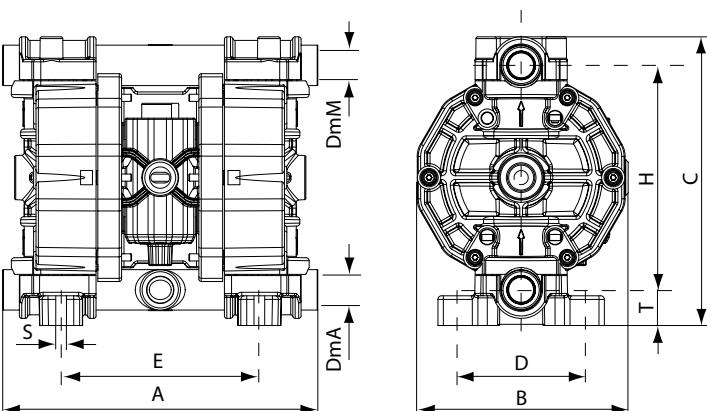
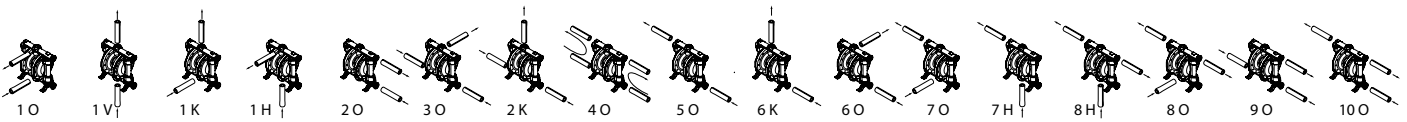

table 14

Technical Data	
Max. capacity	100 l/min
Max. head	70 m
Air Inlet	3/8" BSP
Suction Lift	6 m
Max. Solids	3,5 mm
Max. viscosity (positive suction)	10.000 cP
Pump Materials	
WR - Polypropylene + glass fibre (GFR-PP)	
FC - Polyvinylidene fluoride + carbon fibre (CFF-PVDF)	
DF - Polyvinylidene fluoride (PVDF)	
AL - Aluminum (not available for 100C)	
SS - SUS 316 (not available for 100C)	



DIMENSIONS

table 15

	Plastic						Metal			
	WR		FC - DF		AL	SS				
[mm]	50	75	100C	50	75	100C	50	75	50	75
A	265	291		265	290		265	247		
B	177			177			177	177		
C	246			246			246	249		
D	110			110			110	89		
E	167			167			167	176		
H	189			189			189	185		
S	9			9			9	9		
T	30			30			30	40		
Weight [kg]	6,5			7			7		9	
Connections	Threads (")									
DnA = DnM	1/2"	3/4"	1"	1/2"	3/4"	1"	1/2"	3/4"	1/2"	3/4"
(") ISO-ANSI flanged connections available on request										

DDA 100 - 125 1" - 1 1/4"

Zone 2 



PUMP IDENTIFICATION LABEL

table 16

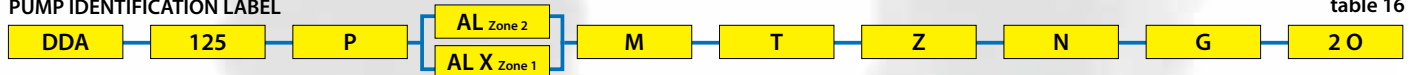

MODEL				MATERIALS						CONNECTIONS									
COD.	SIZE	COD.	DISTRIBUTOR	COD.	FLUID CHAMBER	ATEX zone 1	COD.	DIAPHRAGMS	COD.	BALLS	COD.	SEATS	COD.	O-Rings	COD.	TYPE	SCHEME		
																	COD.	COD.	COD.
100	1"	N	Standard	WR	GFR-PP	X	H	Keyflex®	T	PTFE	K	PVDF	D	EPDM	G	Thread BSP	1O	1V	7H
				FC	CFF-PVDF	X	M	Santoprene®	S	AISI 316	S	AISI 316	V	FKM	N	Thread NPT	1K	1H	8H
				DF	PVDF		D	EPDM	D	EPDM	A	Aluminum	N	NBR	I	Flange (i)	2O	3O	8O
125	1 1/4"	P	Progress	AL	Aluminum	X	N	NBR	N	NBR	Z	PE UHMW	T	PTFE			3K	4O	9O
				SS	AISI 316	X	HT	Keyflex®+PTFE									5O	6K	10O
							MT	Santoprene®+PTFE									6O	7O	

 Only ATEX Zone 2 - (1) Available on request -  Standard connections scheme



DDA 100 (1")

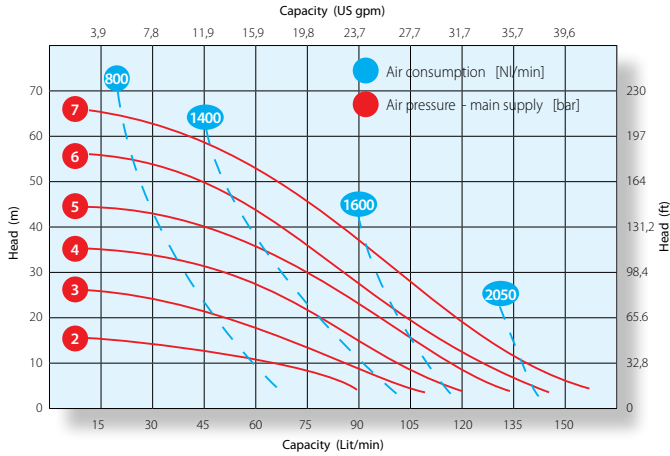

table 17

Technical Data	
Max. capacity	165 l/min
Max. head	70 m
Air Inlet	1/2" BSP
Suction Lift	6 m
Max. Solids	7,5 mm
Max. viscosity (positive suction)	15.000 cP
Pump Materials	
WR - Polypropylene + glass fibre (GFR-PP)	
FC - Polyvinylidene fluoride + carbon fibre (CFF-PVDF)	
DF - Polyvinylidene fluoride (PVDF)	
AL - Aluminum	
SS - SUS 316	

DDA 125 (1 1/4")

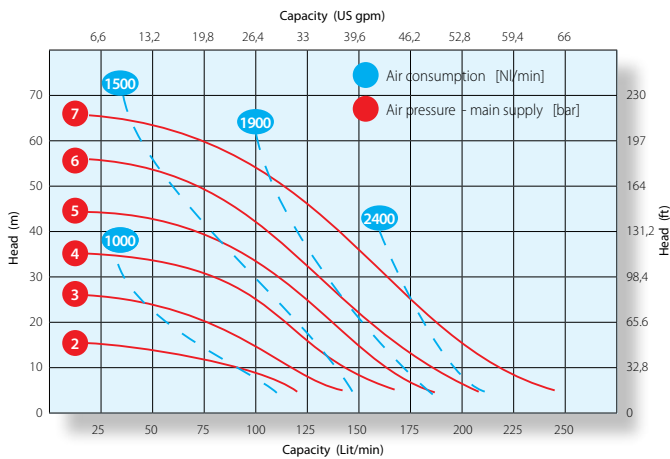
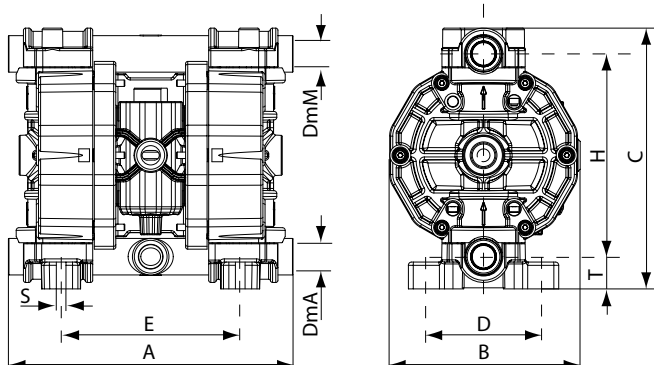
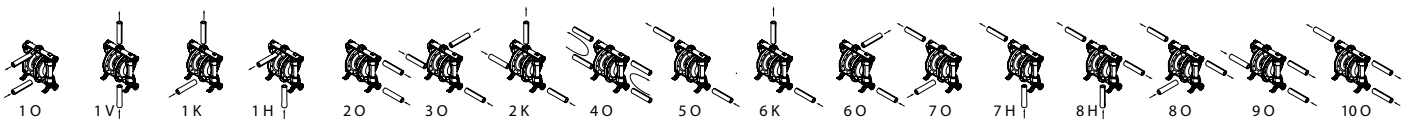

table 18

Technical Data	
Max. capacity	250 l/min
Max. head	70 m
Air Inlet	1/2" BSP
Suction Lift	6 m
Max. Solids	7,5 mm
Max. viscosity (positive suction)	15.000 cP
Pump Materials	
WR - Polypropylene + glass fibre (GFR-PP)	
FC - Polyvinylidene fluoride + carbon fibre (CFF-PVDF)	
DF - Polyvinylidene fluoride (PVDF)	
AL - Aluminum	
SS - SUS 316	



DIMENSIONS

table 19

	Thermoplastic				Metallic			
	WR		FC - DF		AL		SS	
[mm]	100	125	100	125	100	125	100	125
A	370	370	370	370	370	370	359	359
B	222	222	222	222	222	222	222	222
C	365	365	365	365	370	370	348	348
D	155	155	155	155	155	155	129	129
E	231	231	231	231	231	231	254	254
H	292	292	292	292	292	292	272	272
S	9	9	9	9	9	9	9	9
T	39	39	39	39	39	39	46	46
Weight [kg]	15		16		16		20	
Connections	Threads (°)							
DnA = DnM	1"	1 1/4"	1"	1 1/4"	1"	1 1/4"	1"	1 1/4"
(°) ISO-ANSI flanged connections available on request								

DDA 150 - 200 1 1/2" - 2"

Zone 2 

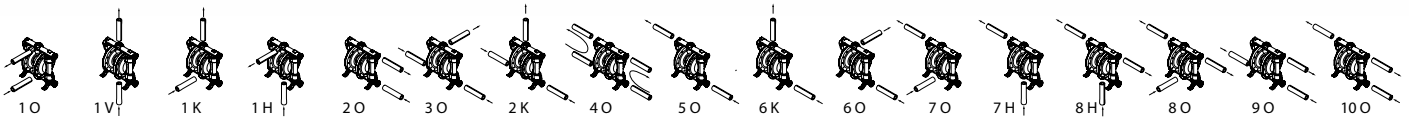
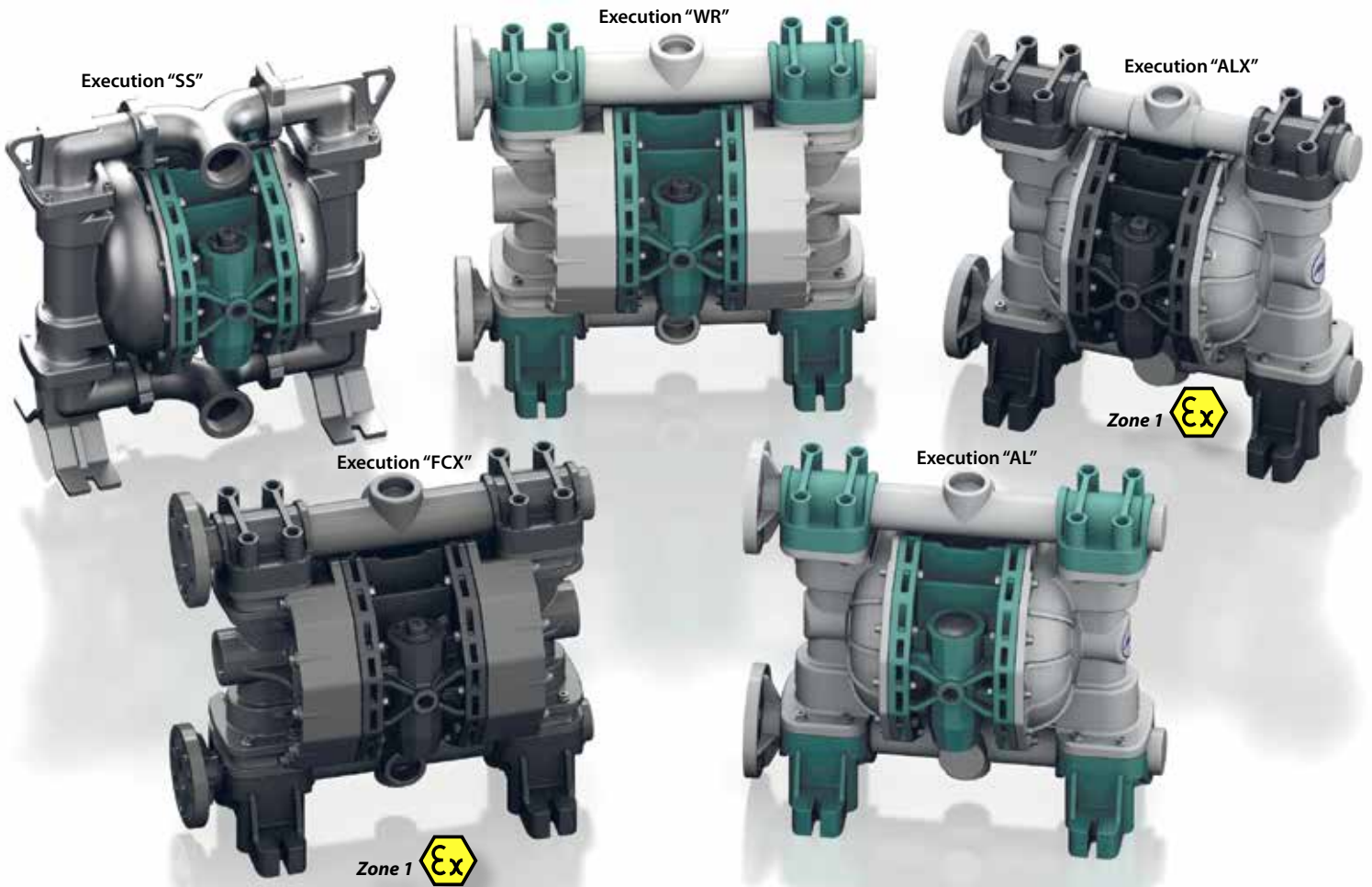

PUMP IDENTIFICATION LABEL

table 20

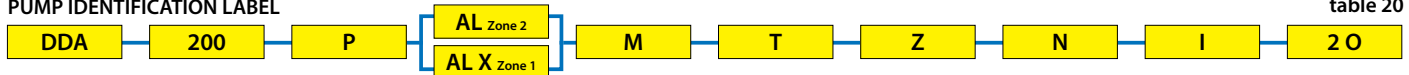

MODEL				MATERIALS						CONNECTIONS											
COD.	SIZE	COD.	DISTRIBUTOR	COD.	FLUID CHAMBER	ATEX zone 1	COD.	DIAPHRAGMS	COD.	BALLS	COD.	SEATS	COD.	O-Rings	COD.	TYPE	SCHEME				
																	COD.	COD.	COD.		
150	1 1/2"	N	Standard	WR	PP+V	X	H	Keyflex®	T	PTFE	K	PVDF	D	EPDM	G	Thread BSP (1)	1O	1V	7H		
				FC	PVDF+C	X	M	Santoprene®	S	AISI 316	S	AISI 316	V	FKM	N	Thread NPT (1)	1K	1H	8H		
				AL	Aluminum	X	D	EPDM	D	EPDM	A	Aluminum	N	NBR	I	Flange (2)	2O	3O	8O		
200	2"	P	Progress	SS	AISI 316	X	N	NBR	N	NBR	Z	PE UHMW	T	PTFE			3K	4O	9O		
							HT	Keyflex®+PTFE											5O	6K	10O
							MT	Santoprene®+PTFE												6O	7O

 Only ATEX Zone 2 - (1) Available on request for WR - FC - AL - (2) Available on request for SS -  Standard connections scheme



DDA 150 (1 1/2")

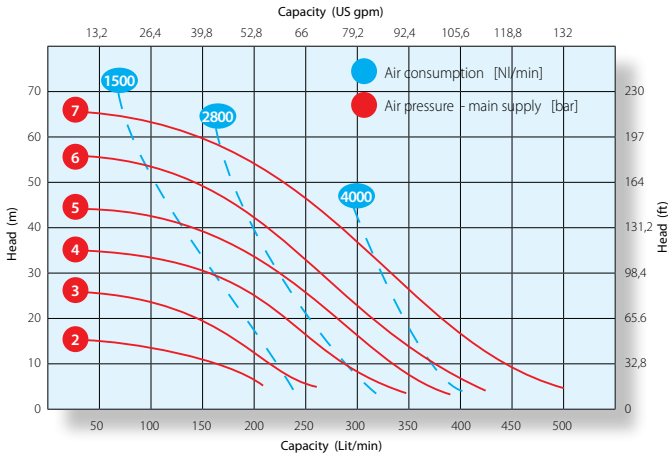

table 21

Technical Data	
Max. capacity	500 l/min
Max. head	70 m
Air Inlet	3/4" BSP
Suction Lift	6 m
Max. Solids	8,5 mm
Max. viscosity (positive suction)	40.000 cP
Pump Materials	
WR - Polypropylene + glass fibre (GFR-PP)	
FC - Polyvinylidene fluoride + carbon fibre (CFF-PVDF)	
AL - Aluminum	
SS - SUS 316	

DDA 200 (2")

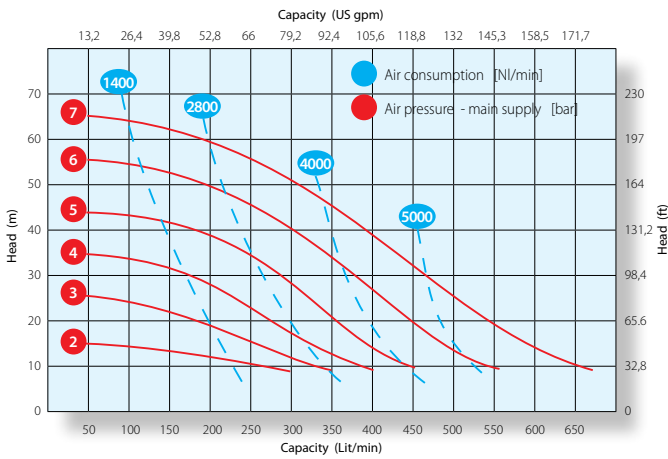
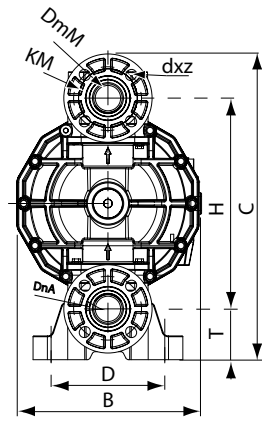
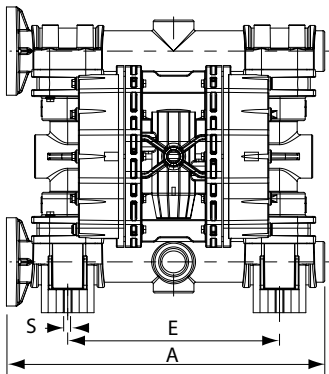

table 22

Technical Data	
Max. capacity	680 l/min
Max. head	70 m
Air Inlet	3/4" BSP
Suction Lift	6 m
Max. Solids	8,5 mm
Max. viscosity (positive suction)	50.000 cP
Pump Materials	
WR - Polypropylene + glass fibre (GFR-PP)	
FC - Polyvinylidene fluoride + carbon fibre (CFF-PVDF)	
AL - Aluminum	
SS - SUS 316	

Termoplastico



Metallo

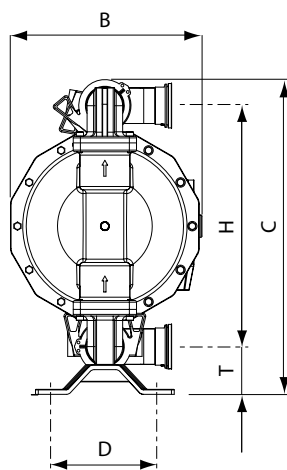
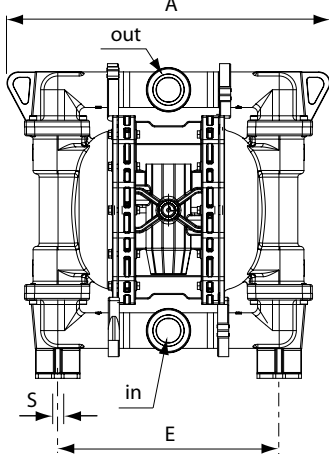

DIMENSIONS

table 23

	Thermoplastic				Metallic			
	WR		FC - DF		AL		SS	
[mm]	150	200	150	200	150	200	150	200
A	595		595		595		582	
B	340		340		345		345	
C	565	572	565	572	568	572	567	
D	213		213		213		203	
E	396		369		396		399	
H	394		394		394		434	
S	12,5		12,5		12,5		12,5	
T	95		95		95		86	
Weight [kg]	30		35		35	36	58	60
Connections	Flanged (!)						Threaded (2)	
DnA = DnM	1 1/2"	2"	1 1/2"	2"	1 1/2"	2"	1 1/2"	2"
KM	iso	110	125	110	125	110	125	/
	ansi	18x4	18x4	18x4	18x4	18x4	18x4	
dxz	iso	98	121	98	121	98	121	/
	ansi	16x4	19x4	16x4	19x4	16x4	19x4	

(!) Available threads connections - (2) available ISO-ANSI flange connections

Astrafood DFA 75 - 125 - 150 - 200 1" - 1 1/2" - 2" - 2 1/2"

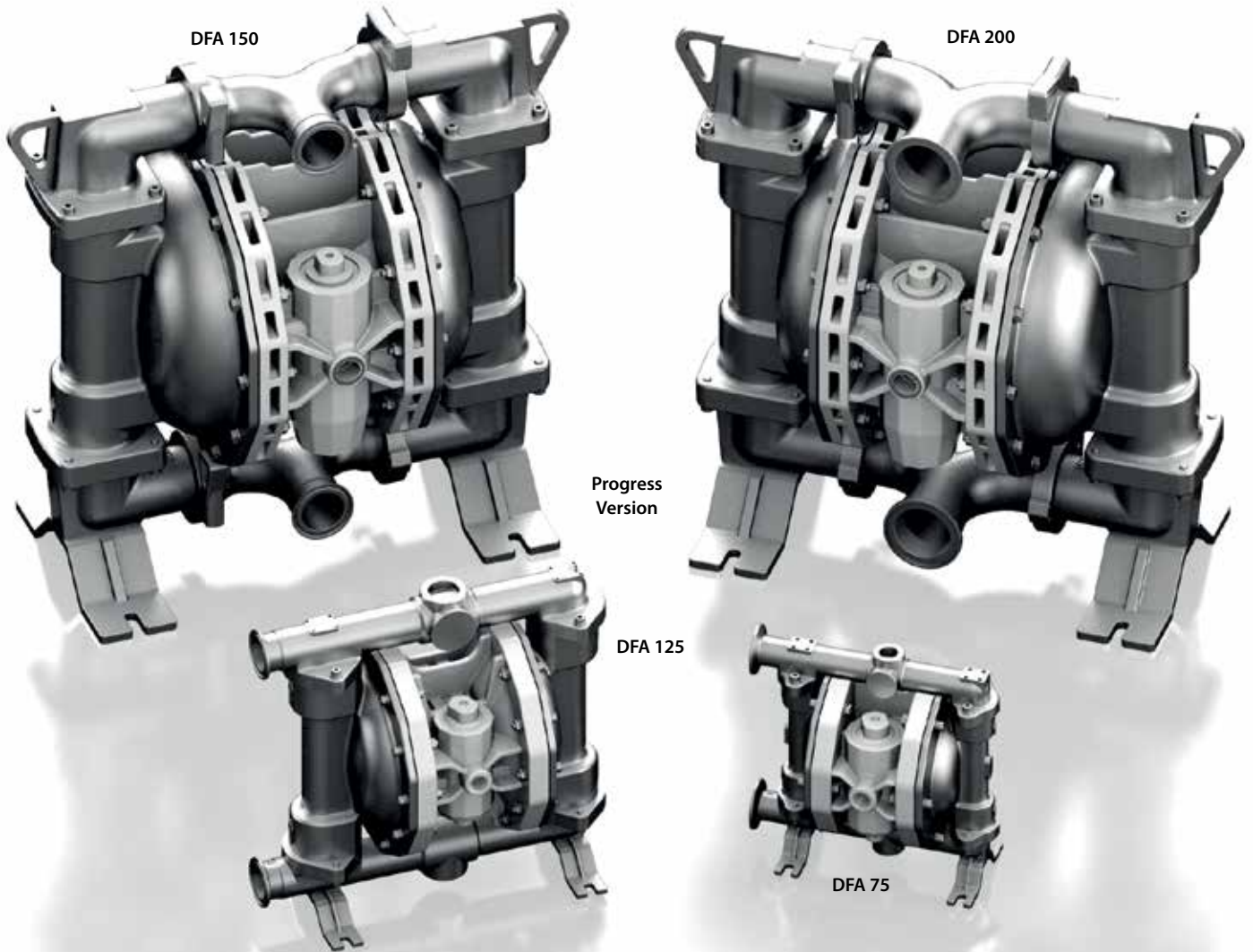

FDA

compliant

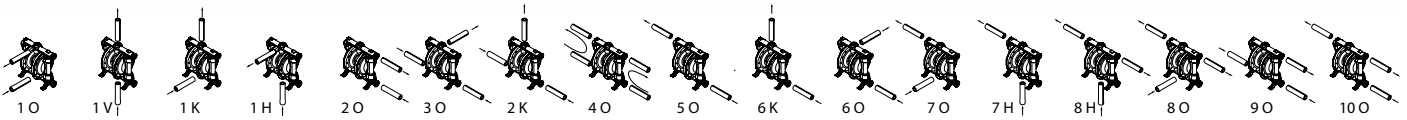

PUMP IDENTIFICATION LABEL

table 24

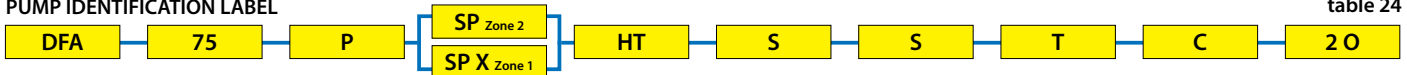

MODEL				MATERIALS						CONNECTIONS									
COD.	SIZE	COD.	DISTRIBUTOR	COD.	FLUID CHAMBER	ATEX zone 1	COD.	DIAPHRAGMS	COD.	BALLS	COD.	SEATS	COD.	O-Rings	COD.	TYPE	SCHEME		
																	COD.	COD.	COD.
50C	1"	N	Standard	P	AISI 316 polished	X	HT	Keyflex®+PTFE	T	PTFE	S	AISI 316	D	EPDM	C	Clamp	10	1V	7H
75	1"																1K	1H	8H
125	1 1/2"	P	Progress						20	30							80		
150	2"								3K	40							90		
200	2 1/2"			50	6K	100													
				60	70														

☐ Standard connections scheme

DFA 75 - 125 - 150 - 200 1" - 1 1/2" - 2" - 2 1/2"

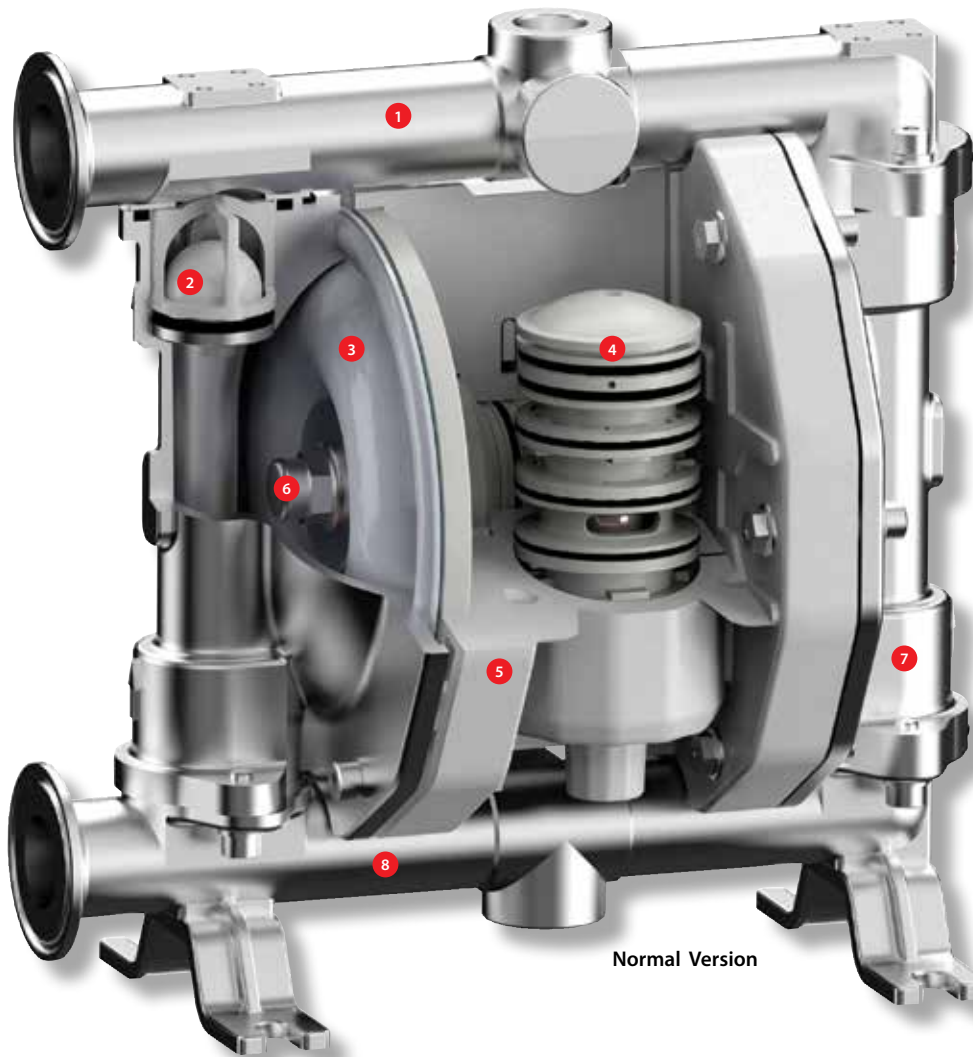
Zone 2 

- 1 Delivery manifold
- 2 Ball valve
- 3 Diaphragm
- 4 Air Distributor
- 5 Central casing
- 6 Wetted washer
- 7 Pump casing
- 8 Suction manifold

Normal Version



ASTRAFOOD "DFA" serie thanks to their characteristics and design can be applied for the transfer of fluids deployed in industries as food, the cosmetics, pharmaceuticals, or chemical additives, beverages, dairy, biotechnologies, medical appliances, paint and in all those applications were a quick release clam connection is required or appreciated. Usually are used to transfer or to remove the products from the mixing contains or storage basins or to pack them in bottles or similar containers.

The air operated double diaphragm pumps ASTRAFOOD are constructed with materials compliant to FDA regulation, wet parts of electro polished SUS 316 with surface finish to 125 Ra (average 2,7 μm) (centre line average height 2,7 μm) and PTFE, both certified for food applications.

All ASTRAFOOD pumps comply to ATEX, Zona 2, regulation and are adequate to operate in areas with atmosphere potentially explosive and, with the variant of the conductive executions can operate also in areas classified as ATEX Zone 1.

These pumps are capable to pump fluids with very high viscosity and temperature up to 95°C.

All other constructive and functional characteristics are equal to those of the ASTRA pumps described at page 9 and 10 of this catalogue.

ASTRAFOOD are available in the **Normal** or **Progress** version with the air distributor equipped with the original "Performance regulation valve"

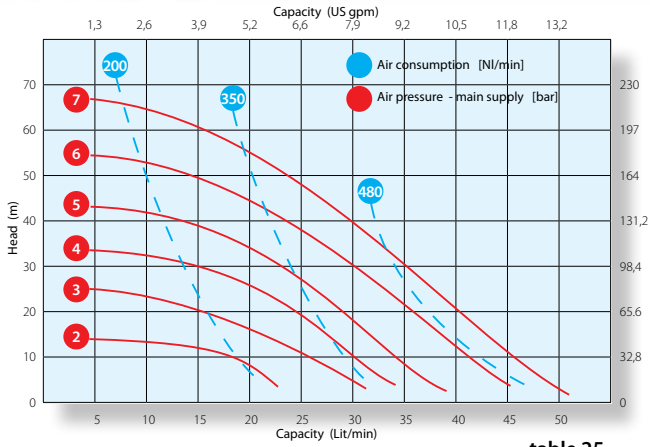

table 25

Dati Tecnici	
Max. capacity	50 l/min
Max. head	70 m
Air Inlet	1/4" BSP
Suction Lift	5 m
Max. Solids	3 mm
Weight	6 Kg
Max. viscosity (positive suction)	10.000 cP

Astrafood DFA 50C (1")

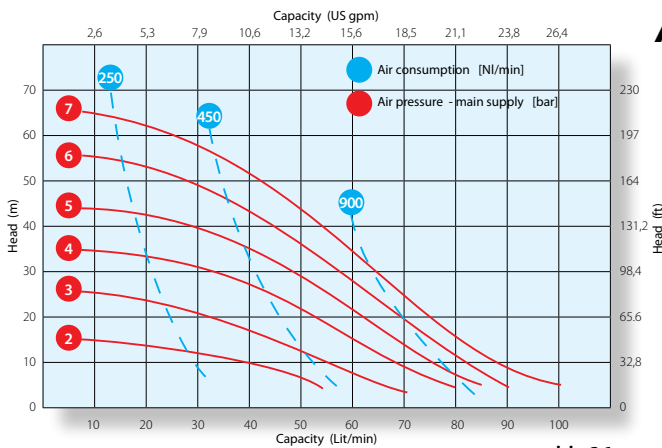

table 26

Dati Tecnici	
Max. capacity	100 l/min
Max. head	70 m
Air Inlet	1/2" BSP
Suction Lift	6 m
Max. Solids	3,5 mm
Weight	9 Kg
Max. viscosity (positive suction)	10.000 cP

Astrafood DFA 75 (1")

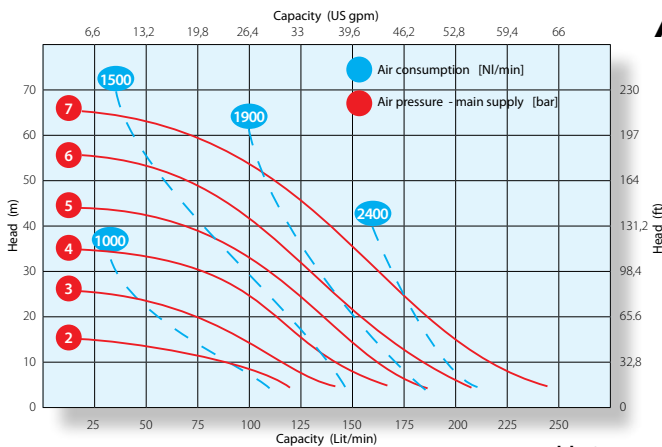

table 27

Dati Tecnici	
Max. capacity	250 l/min
Max. head	70 m
Air Inlet	1/2" BSP
Suction Lift	6 m
Max. Solids	7,5 mm
Weight	20 Kg
Max. viscosity (positive suction)	15.000 cP

Astrafood DFA 125 (1 1/2")



Astraflood DFA 150 (2")

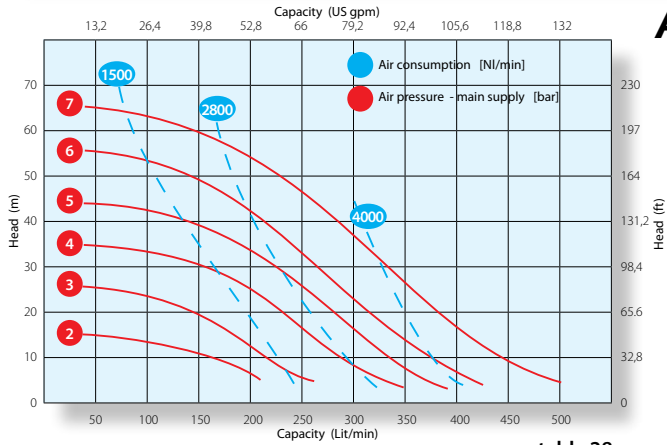

Zone 2



table 28

Dati Tecnici	
Max. capacity	500 l/min
Max. head	70 m
Air Inlet	3/4" BSP
Suction Lift	6 m
Max. Solids	8,5 mm
Weight	58 Kg
Max. viscosity (positive suction)	40.000 cP

Astraflood DFA 200 (2 1/2")

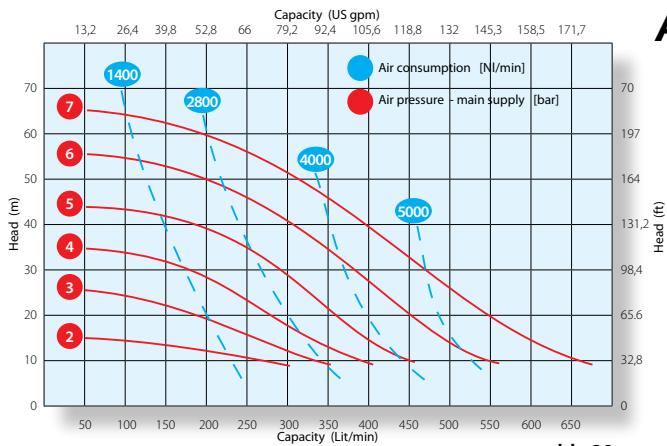

Zone 2



table 29

Dati Tecnici	
Max. capacity	680 l/min
Max. head	70 m
Air Inlet	3/4" BSP
Suction Lift	6 m
Max. Solids	8,5 mm
Weight	60 Kg
Max. viscosity (positive suction)	50.000 cP

DIMENSIONS

table 30

[mm]	SP				
	50C	75	125	150	200
A	225	247	359	582	582
B	156	177	222	345	345
C	230	249	348	567	567
D	110	89	129	203	203
E	110	176	254	399	399
H	183	185	272	434	434
S	7	9	9	12.5	12.5
T	25.5	40	40	40	46
Connections in / out	Clamp* 1"	Clamp* 1"	Clamp* 1 1/2"	Clamp* 2"	Clamp* 2 1/2"

(* Threaded connections available on request)

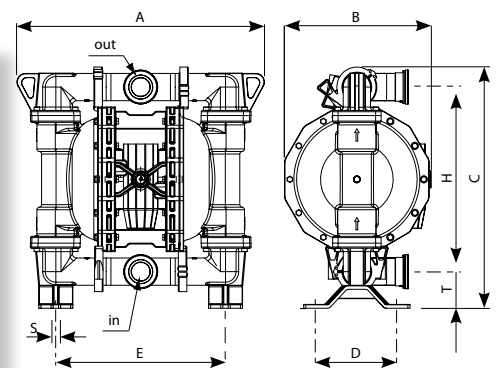
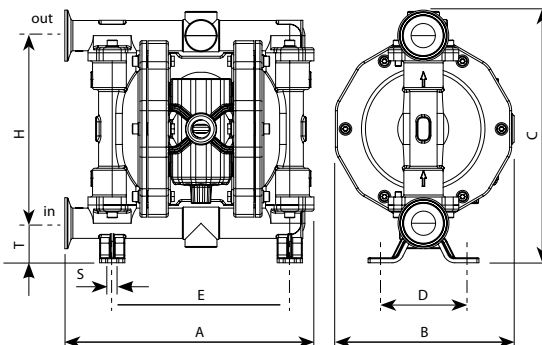

SELENE - pneumatic pulsation dampeners

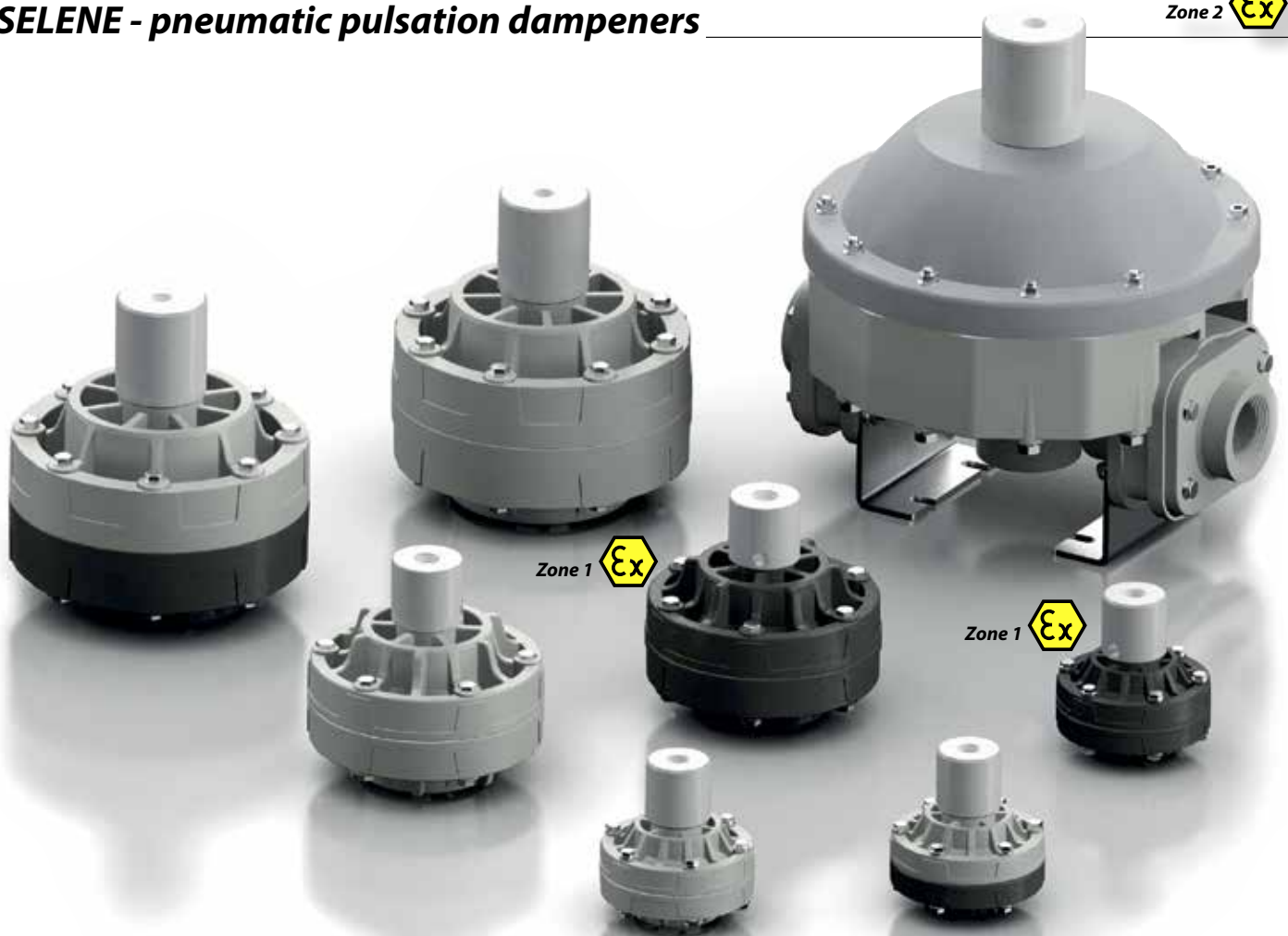
 Zone 2 

CHARACTERISTICS AND ADVANTAGES

The range of **SELENE** flow pulsation dampeners exploits a new technology which minimises the pulsation typical of the flow delivered by air operated double diaphragm pumps. All volumetric pumps as dosing pumps with double diaphragm or plunger piston generate pulsations from their pumping alternative motion and hydraulic shocks potentially capable to damage the complete device.

The pulsation dampeners Selene are mounted on the line where the liquid is delivered and reduce drastically pulsation, liquid hammers and vibration of the pump.

The dampener needs its source of pressurised air supply.

Its use is advised when the hydraulic circuit the pump suffers peaks of pressure, thermal expansions, sudden starts add stops or fast valve shut offs of delivery valves.

SELENE dampeners are "active" and do not need tuning or pre loading for they are self adaptive; they can dampen the amplitude of the pulsations up to 90% of their max. amplitude.

Dampener require a minimal maintenance and are available in the same construction materials of the liquid chambers and diaphragms for thermoplastic pumps and in stainless steel SUS 316 for the metallic versions.

For aluminum made pumps the SELENE dampeners are constructed in PPS (Ryton®).

SELENE dampeners are available in ATEX compliant version and are adequate to operate in areas at risk of explosion areas classified as Atex Zone 1.

Ryton® is a trade mark registered by Chevron Phillips



The major advantages of the Selene dampener are:

- Stabilizes the flow generated by volumetric pumps
- Reduces significantly the vibrations
- Reduces liquid hammers
- Prevents potentially damaging pressure peaks
- Reduces significantly the noise of the system
- Protects the appliances connected along the same hydraulic line
- Reduces the maintenance cost of the plant
- Increases global productivity
- Is adequate to operate with liquids viscous or laden with solids.

PDA - dampener

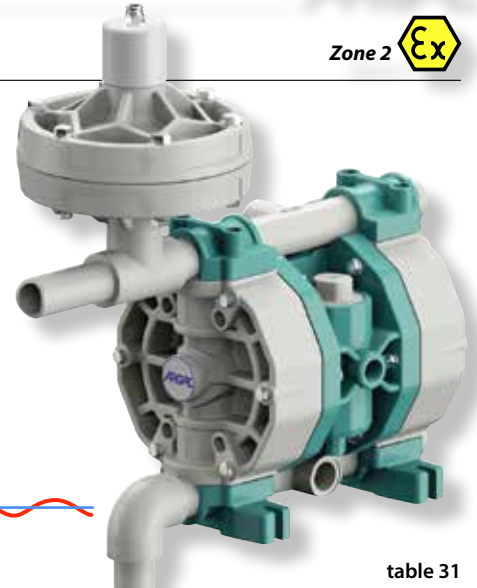
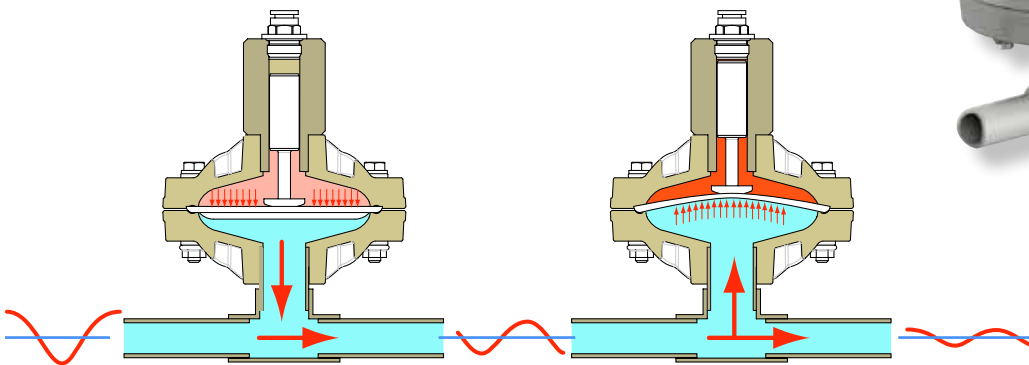

PDA 75

table 31

Technical Data		Materials		Applicability
Inlet / outlet	3/4"	WR - Polypropylene + glass fibre (GFR-PP)		DDA 25R
Air connection	3/8"	FC - Polyvinylidene fluoride + carbon fibre (CFF-PVDF)		DDA 38R
Air exhaust plug	1/4"	DF - Polyvinylidene fluoride (PVDF)		DDA 50R
Max pressure	7 bar	DL - Polyoxymethylene (POMc)		
Dimension	ø 120 x 125 mm	SS - AISI 316		
		SP - AISI 316 polished		

PDA 100

table 32

Technical Data		Materials		Applicability
Inlet / outlet	1"	WR - Polypropylene + glass fibre (GFR-PP)		DDA 50C
Air connection	1/2"	FC - Polyvinylidene fluoride + carbon fibre (CFF-PVDF)		DDA 50
Air exhaust plug	1/4"	DF - Polyvinylidene fluoride (PVDF)		DDA 75
Max pressure	7 bar	DL - Polyoxymethylene (POMc)		DDA 100C
Dimension	ø 182 x 175 mm	SS - AISI 316		
		SP - AISI 316 polished		

PDA 150

table 33

Technical Data		Materials		Applicability
Inlet / outlet	1 1/2"	WR - Polypropylene + glass fibre (GFR-PP)		DDA 100
Air connection	3/8"	FC - Polyvinylidene fluoride + carbon fibre (CFF-PVDF)		DDA 125
Air exhaust plug	1/4"	DF - Polyvinylidene fluoride (PVDF)		
Max pressure	7 bar	DL - Polyoxymethylene (POMc)		
Dimension	ø 231 x 252 mm	SS - AISI 316		
		SP - AISI 316 elettrolucidato		

PDA 200

table 34

Technical Data		Materials		Applicability
Inlet / outlet	2"	WR - Polypropylene + glass fibre (GFR-PP)		DDA 150
Air connection	1/2"	FC - Polyvinylidene fluoride + carbon fibre (CFF-PVDF)		DDA 200
Air exhaust plug	1/2"	AL - Aluminum		
Max pressure	7 bar	SS - AISI 316		
Dimension	ø 350 x 405 mm	SP - AISI 316 polished		

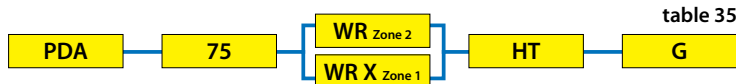
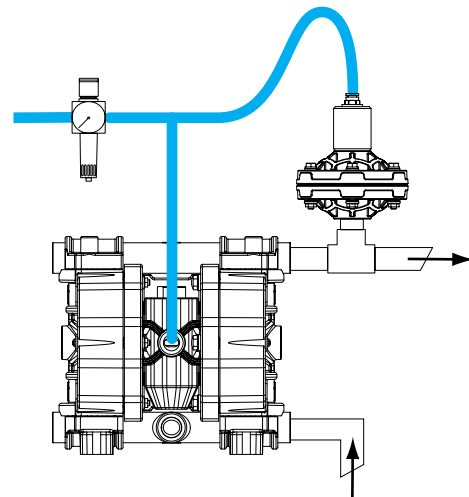

table 35

MODEL		MATERIAL				CONNECTIONS	
COD.	SIZE	COD.	FLUID CHAMBER	ATEX zone 1	COD.	DIAPHRAGMS	COD. TYPE
75	3/4"	WR	GFR-PP	X	H	Keyflex®	G Threaded BSP
		FC	CFF-PVDF	X			
100	1"	DF	PVDF		M	Santoprene®	
		DL	POMc	X			N Threaded NPT
150	1 1/2"	AL	Aluminum	X	HT	Keyflex®+PTFE	
		SS	AISI 316	X			
200	2"	SP	AISI 316 elettrolucidato	X	MT	Santoprene®+PTFE	I Flanged (1)



(1) Available on request

Instructions for the choice of the Astra pumps

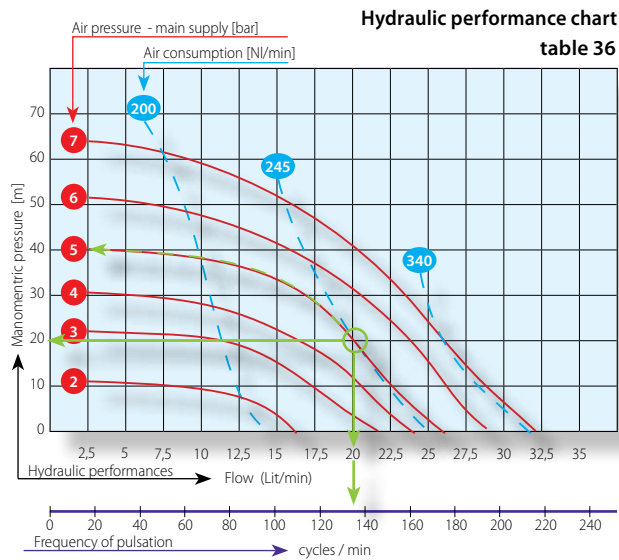

Duty point – example: Flow 20 l/min - Manometric pressure 20 m.

- Air pressure main supply: 5 bar
- Air consumption: 245 NI/min
- Frequency of cycles: 135 cicli/min

Air supply

table 37

Air consumption	Pump intake air pipe external Ø	Air compressor adsorbed power (approx.)
NI / min	mm	HP
50	6	0.5
100	6	1
200	6	2
250	8	2.5
350	8	3.5
450	8	4.5
550	8	5.5
850	10	8.5
1000	10	10
1500	12	15
2000	12	20
3500	12	30
4000	15	40

The power truly adsorbed by the air compressor its appreciatively = 70% of the value indicated in the table

SELF PRIMING

table 38

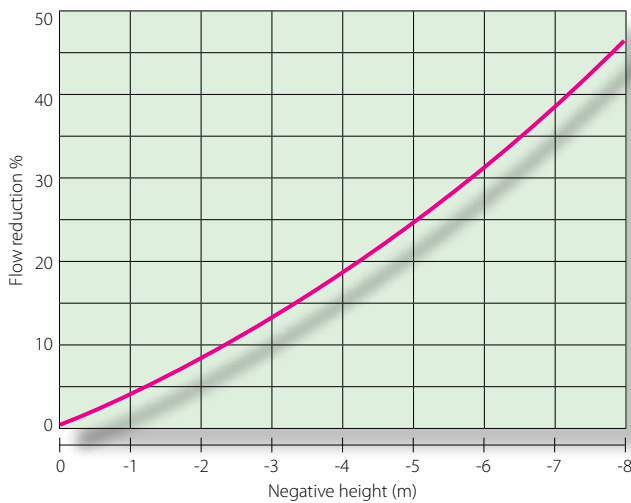

To lift the liquid from a negative height reduces the flow of the pump as in standard circumstances (flooded suction).

The max. negative head is a function of:
 characteristics of the plant (hydraulic losses);
 physical characteristics of the fluid (density, viscosity, boiling point);
 differential pressure exerted on the diaphragms as between the fluid side of the priming diaphragm and the air side of opposite diaphragm.

Relation: % solids – solids dimension

table 39

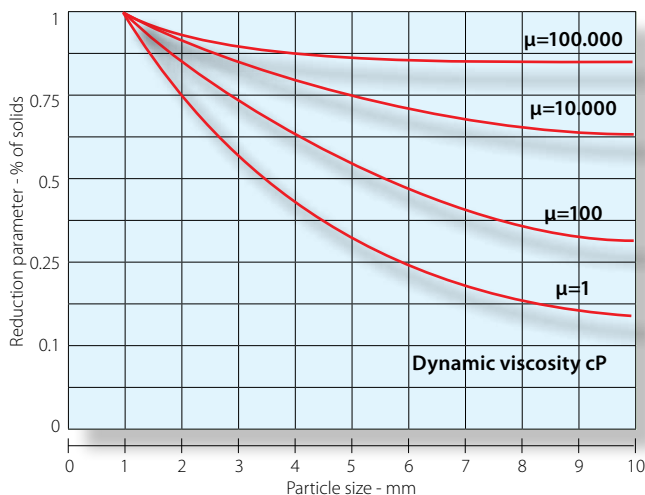

The admissible dimension of solids in suspension depends by:

- DN of the pump (max. valve passage),
- Viscosity of the fluid.

Dimension limits the admissible % concentration of solids in suspension.

Solid particles of larger dimension reduce significantly the max admissible % of solids in suspension if the liquid is low viscosity but do not reduce it much if the liquid is of high viscosity.

Viscous fluids

If the fluid is viscous increase the section (diameter) of the pipe lines by the multiply coefficient reported.

Pipe lines DN

table 40

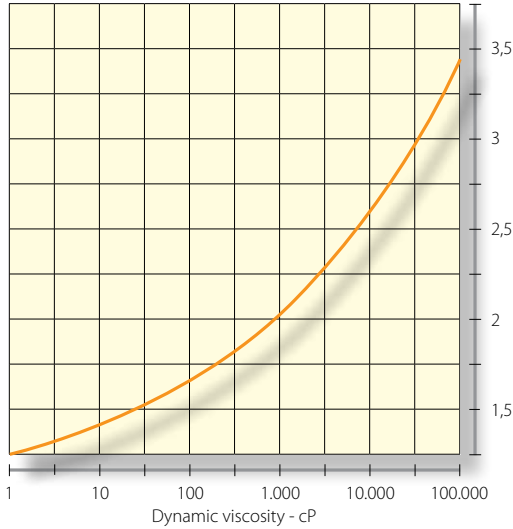

Multiply coefficient for pipe line diameter referred to a non viscous fluid and constant hydraulic losses.

Products viscosity

table 41

Food industry		Cosmetic Pharmaceutical industry		Various Industries	
Product	cP	Product	cP	Product	cP
Butter	50000	Yoothpaste	5000	Oil SAE70	18000
Whipped acid cream	13000	Gel	2000	Pater pul in water	15000
Mayonnaise	6000	Glycerine	1400	Barbotine	2000
Honey	1500 ÷ 3000	Shampoo	250	Grease lubr.	2000
Marmalade	<1000			Mineral oil	800
Tomato sauce	180			Oil SAE30	350
Yogurt	100			Varnish	300
Olive Oil	100				

Viscosity is an important parameter to select the right pump for the application. Viscosity is measured in Centipoise - cP

Viscosity / Cycles / minute

table 42

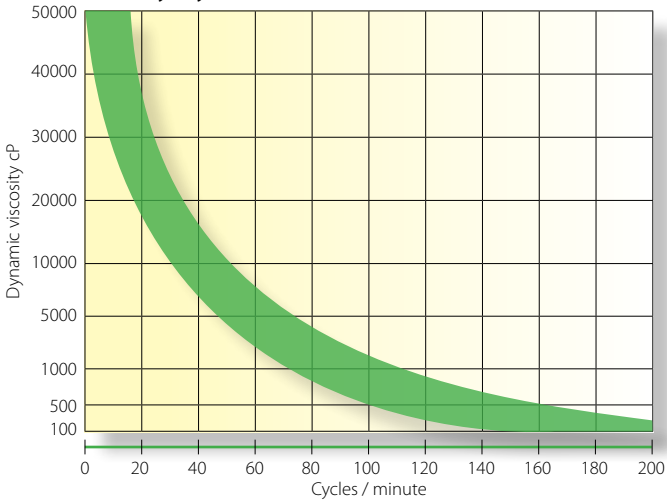

As a general indication assume that; the more viscous the liquid is, the lower is the n° of cycles per minute it has to be pumped at: (cycles per minute = complete cycle of a single diaphragm).

Viscosity

table 43

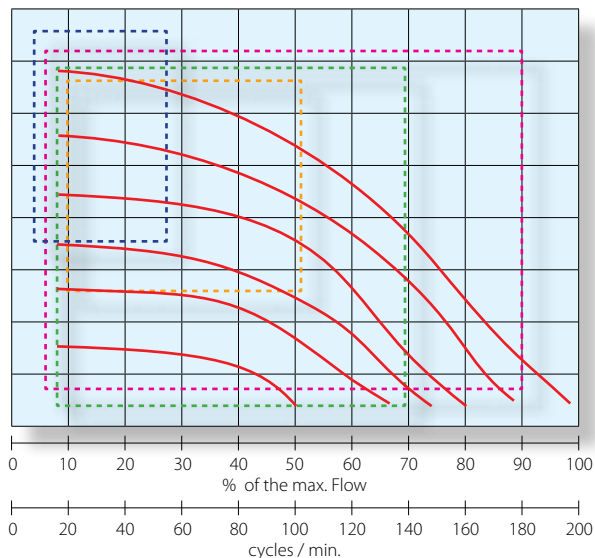

Viscosity of moving fluids can be constant or variable: Fluids with variable viscosity will be pumped within the limits of flow and head inscribed by border line relevant to the specific viscosity characteristic as shown in the attached diagram chart.

- **Not viscous fluids ($1 < \mu < 10$)**
(water, acid solutions, basic solutions, organic solvents).
- **Fluids with constant viscosity**
(sulphuric acid, sodium hydroxide, oil, acetyl ethanolamine, glycerine, toothpaste, mayonnaise, margarine, slurries).
- **Fluids with increasing viscosity**
(corn starch, siliconic oils, row sugar, colloidal dispersion, whipped cream).
- **Fluids with decreasing viscosity**
(paper pulp in water, acrylic paint, latex, blood, ketchup, jellified enamels, jellified hydro carbons, lip gloss).

Main Applications



CHEMICAL &
PETROCHEMICAL



RESINS



PAINT & VARNISH



ELETTROPLATING &
SEMICONDUCTOR



DYEING & LAUNDRY



CERAMICS



COSMETIC



PHARMACEUTICAL



TEXTILE & LEATHER



MINING



LUBRICATING



EXPLOSIVES



WASTE TREATMENT



INKS & PRINT



NAVAL



METALWORKER



CONSTRUCTION
INDUSTRY



ADHESIVES



PULP & PAPER



ENOLOGY



AGRICULTURE & BIOGAS



FOOD AND
DAIRY FACTORIES



DRINKS & LIQUIDS



SUGAR INDUSTRY

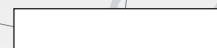

Member of AIB
associazione
industriale
Bresciana

Via Labirinto, 159 - 25125 BRESCIA - ITALY
Tel. +39.030.3507011 - Fax +39.030.3507077 - Export dpt. Tel. +39.030.3507033
Web: www.argal.it - E-mail: export@argal.it

It is the policy of ARGAL to always improve its products and the right is reserved to alter specifications at any time without prior notice.
No part of this publication may be reproduced in any form or any means.